

Компания "**ИНТЕРТУМАШ**" - поставщик оборудования

Kemmler в России.

Kemmler – компания, специализирующаяся на производстве отличного технологического оборудования. Направление работы – инструментальная оснастка для токарных и фрезерных станков различных типов и стандартов.



Для заказа инструмента и технических консультаций оформите заказ на нашем сайте

www.itmash.ru

Наши сотрудники оперативно свяжутся с Вами.

Вы можете присылать Ваши заявки и вопросы на электронную почту

inbox@itmash.ru

или звоните по телефону

(495) 668-13-58.

Вы также можете воспользоваться [формой заявки на сайте](#).



Getreidefelder am Albtrauf · Grain fields at the borderline of the Swabian Alb · Champs de céréales au bord de Jura Souabe

Werkzeugaufnahmen DIN 69893 (HSK)

*Toolholders
DIN 69893 (HSK)*

*Porte-outils
DIN 69893 (HSK)*



Werkzeugaufnahmen DIN 69893-1 (ISO 12164-1) Form A

Toolholders DIN 69893-1 (ISO 12164-1) form A

Porte-outils DIN 69893-1 (ISO 12164-1) forme A

Vorgewuchtet

Pre-balanced
Pré-équilibré

G 6,3 15.000 min⁻¹

G 2,5 Feinwuchten gegen Aufpreis
G 2.5 Fine balancing at extra charge
G 2,5 Equilibrage fin contre un supplément

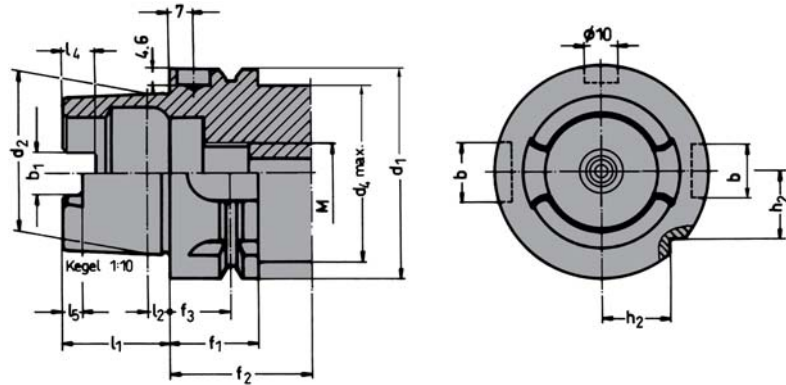

d ₁	d ₂	d ₄	l ₁	l ₂	l ₄	l ₅	M	f ₁	f ₂	f ₃	b ₁	b ₂	b ₃
32	24	26	16	3,2	5,0	3,0	M10 × 1	20	35	16	7,05	7	9
40	30	34	20	4,0	6,0	3,5	M12 × 1	20	35	16	8,05	9	11
50	38	42	25	5,0	7,5	4,5	M16 × 1	26	42	18	10,54	12	14
63	48	53	32	6,3	10,0	6,0	M18 × 1	26	42	18	12,54	16	18
80	60	67	40	8,0	12,0	8,0	M20 × 1,5	26	42	18	16,04	18	20
100	75	85	50	10,0	15,0	10,0	M24 × 1,5	29	45	20	20,02	22	20

Werkstoff: Legierter Einsatzstahl mit einer Zugfestigkeit im Kern von min. 1000 N/mm². Einsatzgehärtet HRC 60 ± 2 (HV 700 ± 50), Härtetiefe 0,8 mm ± 0,2 mm, brüniert und präzisionsgeschliffen.

Genauigkeit: Kegelwinkel – Toleranzqualität < AT 3 nach DIN 7187.

Material: Alloyed case-hardened steel, tensile core strength of min. 1000 N/mm². Case hardened HRC 60 ± 2 (HV 700 ± 50), hardening depth 0.8 mm ± 0.2 mm, black-finished and precisely grinded.

Accuracy: Quality of taper < AT 3 according to DIN 7187.

Matière: Acier de cémentation allié. Résistance à la traction dans le noyau de min 1000 N/mm². Cémentation à HRC 60 ± 2 (HV 700 ± 50), profondeur de cémentation 0,8 mm ± 0,2 mm, bruni et rectifié précisément.

Précision: Qualité du cône < AT 3 suivant DIN 7187.

Inhaltsverzeichnis

Index

Table de matières

DIN 69893-1 HSK A



4.04



4.05



4.07



4.08



4.13



4.14



4.16



4.17



4.18



4.20



4.21



4.22



4.26



4.35



4.36

DIN 69893-1 HSK C

4.39

DIN 69893-5 HSK E

4.55

DIN 69893-6 HSK F

4.69

Spannfutter für Spannzangen DIN 6388 (ISO 10897) System OZ

DIN 69893-1 HSK A

Collet chucks for collets DIN 6388 (ISO 10897) OZ-system

Mandrins à pinces pour pinces DIN 6388 (ISO 10897) système OZ



Verwendung:

Zur Aufnahme von Werkzeugen mit Zylinderschaft in Spannzangen.

Application:

For mounting straight-shank tools in collets.

Application:

Pour le serrage d'outils avec queue cylindrique dans des pinces de serrage.

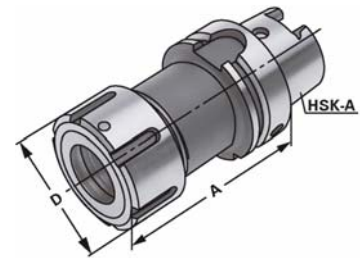

G 6,3 15.000 min⁻¹

≤ 0,003

INFO → 10.03

Bestell-Nr. Order no. Référence	HSK	Spannbereich Capacity Capacité	A	D
A50.01.16	HSK-A 50	2 – 16 (OZ 16)	90	43
A50.01.25	HSK-A 50	2 – 25 (OZ 25)	110	60
A63.01.16	HSK-A 63	2 – 16 (OZ 16)	100	43
A63.01.25	HSK-A 63	2 – 25 (OZ 25)	100	60
A63.01.32	HSK-A 63	3 – 32 (OZ 32)	120	72
A100.01.16	HSK-A 100	2 – 16 (OZ 16)	110	43
A100.01.25	HSK-A 100	2 – 25 (OZ 25)	120	60
A100.01.32	HSK-A 100	3 – 32 (OZ 32)	130	72

Lieferumfang: Mit kugelgelagerter Spannmutter

Delivery: With ball bearing clamping nut

Livraison: Avec écrou de serrage à roulement à billes



7.04-7.09



7.39



4.36

Spannfutter für Spannzangen DIN 6499 (ISO 15488) System ER

DIN 69893-1 HSK A



Collet chucks for collets DIN 6499 (ISO 15488) ER-system

Mandrins à pinces pour pinces DIN 6499 (ISO 15488) système ER



Verwendung:

Zur Aufnahme von Werkzeugen mit Zylinderschaft in Spannzangen.

Application:

For mounting straight-shank tools in collets.

Application:

Pour le serrage d'outils avec queue cylindrique dans des pinces de serrage.

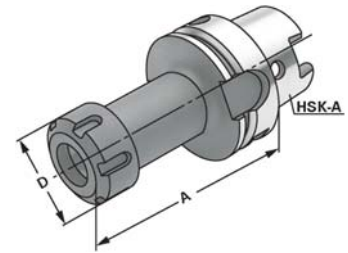

G 6,3 15.000 min⁻¹

≤ 0,003

INFO → 10.03

Bestell-Nr. Order no. Référence	HSK	Spannbereich Capacity Capacité	A	D
A32.02.10	HSK-A 32	1 – 10 (ER 16)	80	32
A32.02.16	HSK-A 32	2 – 16 (ER 25)	80	42
A40.02.10	HSK-A 40	1 – 10 (ER 16)	80	32
A40.02.16	HSK-A 40	2 – 16 (ER 25)	80	42
A40.02.20	HSK-A 40	2 – 20 (ER 32)	80	50
A50.02.10	HSK-A 50	1 – 10 (ER 16)	100	32
A50.02.16	HSK-A 50	2 – 16 (ER 25)	80	42
A50.02.20	HSK-A 50	2 – 20 (ER 32)	100	50
A63.02.10	HSK-A 63	1 – 10 (ER 16)	100	32
A63.02.16	HSK-A 63	2 – 16 (ER 25)	100	42
A63.02.20	HSK-A 63	2 – 20 (ER 32)	100	50
A63.02.26	HSK-A 63	3 – 26 (ER 40)	120	63
A63.02.10.1	HSK-A 63	1 – 10 (ER 16)	160	32
A63.02.16.1	HSK-A 63	2 – 16 (ER 25)	160	42
A63.02.20.1	HSK-A 63	2 – 20 (ER 32)	160	50
A63.02.26.1	HSK-A 63	3 – 26 (ER 40)	160	63
A80.02.20	HSK-A 80	2 – 20 (ER 32)	100	50
A80.02.26	HSK-A 80	3 – 26 (ER 40)	120	63
A100.02.16	HSK-A 100	2 – 16 (ER 25)	100	42
A100.02.20	HSK-A 100	2 – 20 (ER 32)	100	50
A100.02.26	HSK-A 100	3 – 26 (ER 40)	120	63

Lieferumfang: Mit gewuchteter Spannmutter

Delivery: With balanced clamping nut

Livraison: Avec écrou de serrage équilibré



- Das Kemmler Präzisions-Spannzangenfutter ist die Alternative zu Hydro-Dehnspannfuttern und Schrumpfaufnahmen
- Hohe Flexibilität durch austauschbare Spannzangen (Präzisions-Spannzangen System KPS verfügbar von Ø 0,5 bis 16 mm)
- Hohe Spannkräfte und Rundlaufgenauigkeit ergeben eine erstklassige Oberfläche und längere Werkzeugstandzeiten
- Glatte Spannmutter ohne Nuten für Hochgeschwindigkeitsbearbeitung
- Schlanke Ausführung
- Max. Rundlauf-Abweichung 5 µm bei 4×d des eingespannten Werkzeugs
- Standardmäßig feinausgewuchtet (G2,5 30.000 min⁻¹)
- Lieferbar mit den Werkzeugaufnahmen SK 30, SK 40, SK 50 DIN 69871 A, JIS B 6339 (MAS 403 BT), DIN 69893 (HSK-A)
- Montage und Demontage der Spannzangen erfolgt mit einer speziellen Montagehilfe
- Hervorragendes Preis-Leistungsverhältnis



Spannzangen-größe	Spannbereich mm	Ø Stufen mm
D16	0,5–10	0,5
D24	1,0–16	0,5

Montage der KPS-Spannzangen mit der Montagehilfe

1. Die Spannmutter vom Spannfutter lösen.
2. Die Spannzange in die Montagehilfe einsetzen.
3. Die Spannzange mit der Montagehilfe bis zum Anschlag in die Spannmutter einschieben.
4. Die Montagehilfe ausklinken.
5. Die Spannmutter mit der Spannzange auf das Spannfutter montieren.



Demontage

Setzen Sie die Spannzange zusammen mit der Spannmutter in die Montagehilfe ein, um die Spannzange zusammenzudrücken. Anschließend die Spannmutter entfernen.



KPS-Spannzange



KPS-Montagehilfe*



KPS-Spannmutter*



KPS-Spannschlüssel*

* Patent geschützt

Spannfutter für Spannzangen System KPS

Collet chucks for collets KPS-system

Mandrins à pinces pour pinces système KPS

DIN 69893-1 HSK A



G 2,5 30.000 min⁻¹

≤ 0,003

Verwendung:

Zur Aufnahme von Werkzeugen mit Zylinderschaft in Spannzangen.

Für Anwendungen im HSC-Bereich und für hochpräzise Bearbeitungsergebnisse.

Application:

For mounting straight-shank tools in collets.
To use for high speed cutting and high precision milling.

Application:

Pour le serrage d'outils avec queue cylindrique dans des pinces de serrage.

Pour l'usage dans le coupage à grande vitesse et dans l'usinage à grande précision.

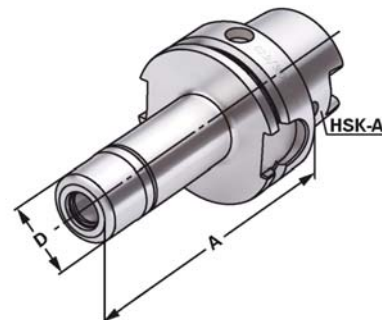

INFO → 10.03

Bestell-Nr. Order no. Référence	HSK	Spannbereich Capacity Capacité	A	D
A63.03.10	HSK-A 63	3 – 10 (KPS 10)	100	27,5
A63.03.16	HSK-A 63	4 – 16 (KPS 16)	120	40,0

Lieferumfang: Mit gewuchteter Spannmutter

Delivery: With balanced clamping nut

Livraison: Avec écrou de serrage équilibré





Verwendung:

Zum Spannen von zylindrischen Werkzeugschäften mit seitlicher Spannfläche nach DIN 1835 Form B (Weldon).

Application:

For mounting straight-shank tools with flat according to DIN 1835 form B (Weldon).

Application:

Pour le serrage d'outils avec queue cylindrique et avec méplat suivant DIN 1835 forme B (Weldon).

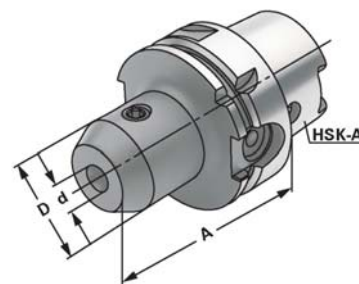

G 6,3 15.000 min⁻¹

≤ 0,003

Bestell-Nr. Order no. Référence	HSK	d ^{H4}	A	D
A32.04.06	HSK-A 32	6	60	25
A32.04.08	HSK-A 32	8	60	28
A32.04.10	HSK-A 32	10	65	35
A32.04.12	HSK-A 32	12	70	42
A40.04.06	HSK-A 40	6	60	25
A40.04.08	HSK-A 40	8	60	28
A40.04.10	HSK-A 40	10	60	35
A40.04.12	HSK-A 40	12	70	42
A40.04.16	HSK-A 40	16	75	48
A50.04.06	HSK-A 50	6	65	25
A50.04.08	HSK-A 50	8	65	28
A50.04.10	HSK-A 50	10	65	35
A50.04.12	HSK-A 50	12	80	42
A50.04.14	HSK-A 50	14	80	44
A50.04.16	HSK-A 50	16	80	48
A50.04.18	HSK-A 50	18	80	50
A50.04.20	HSK-A 50	20	80	52
A63.04.06	HSK-A 63	6	65	25
A63.04.08	HSK-A 63	8	65	28
A63.04.10	HSK-A 63	10	65	35
A63.04.12	HSK-A 63	12	80	42
A63.04.14	HSK-A 63	14	80	44
A63.04.16	HSK-A 63	16	80	48
A63.04.18	HSK-A 63	18	80	50
A63.04.20	HSK-A 63	20	80	52
A63.04.25	HSK-A 63	25	110	65
A63.04.32	HSK-A 63	32	110	72
A63.04.40	HSK-A 63	40	125	80

Hinweis: Ab d = 25 mit zwei Spannschrauben
Note: From d = 25 on two clamping screws
Observation: A partir de d = 25 avec deux vis de serrage

Lieferumfang: Mit Spannschraube
Delivery: With clamping screw
Livraison: Avec vis de serrage

Fräseraufnahmen DIN 6359 für Zylinderschäfte DIN 1835-B DIN 69893-1 HSK A

End mill holders DIN 6359 for end mills DIN 1835-B

Porte-fraises DIN 6359 pour queues cylindriques DIN 1835-B



Verwendung:

Zum Spannen von zylindrischen Werkzeugschäften mit seitlicher Spannfläche nach DIN 1835 Form B (Weldon).

Application:

For mounting straight-shank tools with flat according to DIN 1835 form B (Weldon).

Application:

Pour le serrage d'outils avec queue cylindrique et avec méplat suivant DIN 1835 forme B (Weldon).

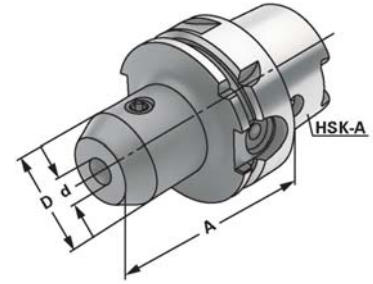

G 6,3 15.000 min⁻¹

≤ 0,003

Bestell-Nr. Order no. Référence	HSK	d ^{H4}	A	D
A63.04.06.1	HSK-A 63	6	100	25
A63.04.08.1	HSK-A 63	8	100	28
A63.04.10.1	HSK-A 63	10	100	35
A63.04.12.2	HSK-A 63	12	160	35
A63.04.14.2	HSK-A 63	14	160	44
A63.04.16.2	HSK-A 63	16	160	48
A63.04.18.2	HSK-A 63	18	160	50
A63.04.20.2	HSK-A 63	20	160	52
A80.04.06	HSK-A 80	6	80	25
A80.04.08	HSK-A 80	8	80	28
A80.04.10	HSK-A 80	10	80	35
A80.04.12	HSK-A 80	12	80	42
A80.04.14	HSK-A 80	14	80	44
A80.04.16	HSK-A 80	16	100	48
A80.04.18	HSK-A 80	18	100	50
A80.04.20	HSK-A 80	20	100	52
A80.04.25	HSK-A 80	25	100	65
A80.04.32	HSK-A 80	32	110	72
A100.04.06	HSK-A 100	6	80	25
A100.04.08	HSK-A 100	8	80	28
A100.04.10	HSK-A 100	10	80	35
A100.04.12	HSK-A 100	12	80	42
A100.04.14	HSK-A 100	14	80	44
A100.04.16	HSK-A 100	16	100	48
A100.04.18	HSK-A 100	18	100	50
A100.04.20	HSK-A 100	20	100	52
A100.04.25	HSK-A 100	25	100	65
A100.04.32	HSK-A 100	32	100	72
A100.04.40	HSK-A 100	40	105	80

Hinweis: Ab d = 25 mit zwei Spannschrauben
Note: From d = 25 on two clamping screws
Observation: A partir de d = 25 avec deux vis de serrage

Lieferumfang: Mit Spannschraube
Delivery: With clamping screw
Livraison: Avec vis de serrage



End mill holders DIN 6359 with coolant channels for end mills DIN 1835-B

Porte-fraises DIN 6359 avec canaux d'arrosage pour queues cylindriques DIN 1835-B



Verwendung:

Zum Spannen von zylindrischen Werkzeugschäften mit seitlicher Spannfläche nach DIN 1835 Form B (Weldon). Mit Kühlkanälen für optimale Kühlung der Werkzeugschneide.

Application:

For mounting straight-shank tools with flat according to DIN 1835 form B (Weldon). With coolant channels for optimal coolant at the cutting edge.

Application:

Pour le serrage d'outils avec queue cylindrique et avec méplat suivant DIN 1835 forme B (Weldon). Avec canaux d'arrosage pour un refroidissement optimal aux lames.

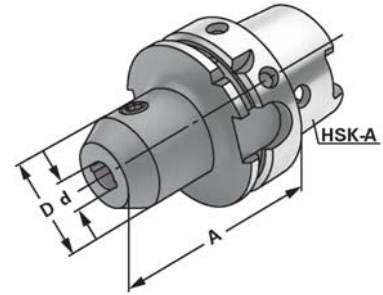

G 6,3 15.000 min⁻¹

≤ 0,003

Bestell-Nr. Order no. Référence	HSK	d ^{H4}	A	D
A63.04.06.K	HSK-A 63	6	65	25
A63.04.08.K	HSK-A 63	8	65	28
A63.04.10.K	HSK-A 63	10	65	35
A63.04.12.K	HSK-A 63	12	80	42
A63.04.14.K	HSK-A 63	14	80	44
A63.04.16.K	HSK-A 63	16	80	48
A63.04.18.K	HSK-A 63	18	80	50
A63.04.20.K	HSK-A 63	20	80	52
A63.04.25.K	HSK-A 63	25	110	65
A63.04.32.K	HSK-A 63	32	110	72
A63.04.40.K	HSK-A 63	40	125	80
A100.04.06.K	HSK-A 100	6	80	25
A100.04.08.K	HSK-A 100	8	80	28
A100.04.10.K	HSK-A 100	10	80	35
A100.04.12.K	HSK-A 100	12	80	42
A100.04.14.K	HSK-A 100	14	80	44
A100.04.16.K	HSK-A 100	16	100	48
A100.04.18.K	HSK-A 100	18	100	50
A100.04.20.K	HSK-A 100	20	100	52
A100.04.25.K	HSK-A 100	25	100	65
A100.04.32.K	HSK-A 100	32	100	72
A100.04.40.K	HSK-A 100	40	105	80

Hinweis: Ab d = 25 mit zwei Spanschrauben
d = 6 bis 14 mit zwei Kühlkanälen
d = 16 bis 40 mit vier Kühlkanälen
Für Werkzeuge mit innerer Kühlmittelzufuhr muss ein O-Ring eingesetzt werden.

Note: From d = 25 on two clamping screws
d = 6 to 14 with two coolant channels
d = 16 to 40 with four coolant channels
For tools with through coolant an O-ring must be used.

Observation: A partir de d = 25 avec deux vis de serrage
d = 6 bis 14 avec deux canaux d'arrosage
d = 16 bis 40 avec quatre canaux d'arrosage
Pour outils avec arrosage interne il faut utiliser un joint torique.

Lieferumfang: Mit Spanschraube und O-Ring
Delivery: With clamping screw and O-ring
Livraison: Avec vis de serrage et joint torique



Fräseraufnahmen DIN 6359 für Zylinderschäfte DIN 1835-E **DIN 69893-1 HSK A**

End mill holders DIN 6359 for end mills DIN 1835-E

Porte-fraises DIN 6359 pour queues cylindriques DIN 1835-E



Verwendung:

Zum Spannen von zylindrischen Werkzeugschäften mit geneigter Spannfläche nach DIN 1835 Form E (Whistle Notch).

Application:

For mounting straight-shank tools and inclined flat according to DIN 1835 form E (Whistle Notch).

Application:

Pour le serrage d'outils avec queue cylindrique et avec méplat incliné suivant DIN 1835 forme E (Whistle Notch).

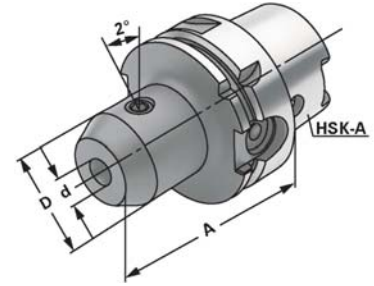

G 6,3 15.000 min⁻¹

≤ 0,003

Bestell-Nr. Order no. Référence	HSK	d ^{H4}	A	D
A32.05.06	HSK-A 32	6	80	25
A32.05.08	HSK-A 32	8	80	28
A32.05.10	HSK-A 32	10	80	35
A40.05.06	HSK-A 40	6	80	25
A40.05.08	HSK-A 40	8	80	28
A40.05.10	HSK-A 40	10	80	35
A40.05.12	HSK-A 40	12	90	42
A40.05.14	HSK-A 40	14	90	44
A40.05.16	HSK-A 40	16	90	48
A50.05.06	HSK-A 50	6	80	25
A50.05.08	HSK-A 50	8	80	28
A50.05.10	HSK-A 50	10	80	35
A50.05.12	HSK-A 50	12	90	42
A50.05.14	HSK-A 50	14	90	44
A50.05.16	HSK-A 50	16	90	48
A50.05.18	HSK-A 50	18	90	50
A50.05.20	HSK-A 50	20	100	52
A63.05.06	HSK-A 63	6	80	25
A63.05.08	HSK-A 63	8	80	28
A63.05.10	HSK-A 63	10	80	35
A63.05.12	HSK-A 63	12	90	42
A63.05.14	HSK-A 63	14	90	44
A63.05.16	HSK-A 63	16	100	48
A63.05.18	HSK-A 63	18	100	50
A63.05.20	HSK-A 63	20	100	52
A63.05.25	HSK-A 63	25	110	65
A63.05.32	HSK-A 63	32	110	72

Hinweis: Ab d = 25 mit zwei Spannschrauben
Note: From d = 25 on two clamping screws
Observation: A partir de d = 25 avec deux vis de serrage

Lieferumfang: Mit Spannschraube und axialer Verstellechraube
Delivery: With clamping screw and axial adjustment bolt
Livraison: Avec vis de serrage et vis de butée axiale



Verwendung:

Zum Spannen von zylindrischen Werkzeugschäften mit geneigter Spannfläche nach DIN 1835 Form E (Whistle Notch).

Application:

For mounting straight-shank tools and inclined flat according to DIN 1835 form E (Whistle Notch).

Application:

Pour le serrage d'outils avec queue cylindrique et avec méplat incliné suivant DIN 1835 forme E (Whistle Notch).

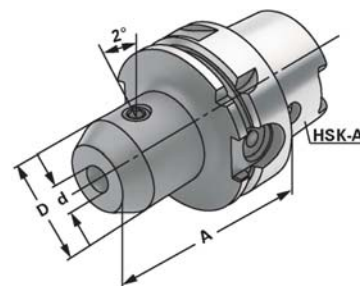
G 6,3 15.000 min⁻¹
↗ ≤ 0,003

Bestell-Nr. Order no. Référence	HSK	d ^{H4}	A	D
A80.05.06	HSK-A 80	6	90	25
A80.05.08	HSK-A 80	8	90	28
A80.05.10	HSK-A 80	10	90	35
A80.05.12	HSK-A 80	12	100	42
A80.05.14	HSK-A 80	14	100	44
A80.05.16	HSK-A 80	16	100	48
A80.05.18	HSK-A 80	18	100	50
A80.05.20	HSK-A 80	20	110	52
A80.05.25	HSK-A 80	25	110	65
A80.05.32	HSK-A 80	32	120	72
A100.05.06	HSK-A 100	6	90	25
A100.05.08	HSK-A 100	8	90	28
A100.05.10	HSK-A 100	10	90	35
A100.05.12	HSK-A 100	12	100	42
A100.05.14	HSK-A 100	14	100	44
A100.05.16	HSK-A 100	16	100	48
A100.05.18	HSK-A 100	18	100	50
A100.05.20	HSK-A 100	20	110	52
A100.05.25	HSK-A 100	25	120	65
A100.05.32	HSK-A 100	32	120	72
A100.05.40	HSK-A 100	40	120	80

Hinweis: Ab d = 25 mit zwei Spannschrauben

Note: From d = 25 on two clamping screws

Observation: A partir de d = 25 avec deux vis de serrage

Lieferumfang: Mit Spannschraube und axialer Verstellemschraube

Delivery: With clamping screw and axial adjustment bolt

Livraison: Avec vis de serrage et vis de butée axiale



Kombi-Aufsteckfräserdorne DIN 6358

Combi shell mill holders DIN 6358

Porte-fraises à double usage DIN 6358

DIN 69893-1 HSK A



Verwendung:

Zur Aufnahme von Walzen-, Walzenstirnfräsern oder Messerköpfen mit Längs- oder Quernut.

Application:

For mounting milling cutters with transverse or longitudinal groove.

Application:

Pour le serrage de fraises à rainure transversale ou à rainure longitudinale.

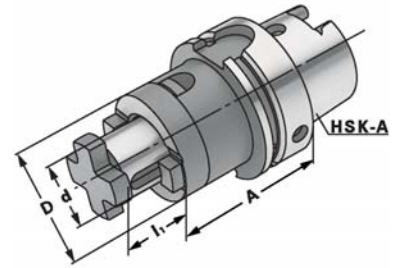

G 6,3 15.000 min⁻¹

≤ 0,005

Bestell-Nr. Order no. Référence	HSK	d _{h6}	A	l ₁	D
A32.10.16	HSK-A 32	16	55	17	32
A32.10.22	HSK-A 32	22	55	19	40
A32.10.27	HSK-A 32	27	65	21	48
A40.10.16	HSK-A 40	16	50	17	32
A40.10.22	HSK-A 40	22	50	19	40
A40.10.27	HSK-A 40	27	65	21	48
A50.10.16	HSK-A 50	16	50	17	32
A50.10.22	HSK-A 50	22	50	19	40
A50.10.27	HSK-A 50	27	65	21	48
A50.10.32	HSK-A 50	32	65	24	58
A63.10.16	HSK-A 63	16	60	17	32
A63.10.22	HSK-A 63	22	60	19	40
A63.10.27	HSK-A 63	27	60	21	48
A63.10.32	HSK-A 63	32	60	24	58
A63.10.40	HSK-A 63	40	70	27	70
A63.10.16.1	HSK-A 63	16	100	17	32
A63.10.22.1	HSK-A 63	22	100	19	40
A63.10.27.1	HSK-A 63	27	100	21	48
A63.10.32.1	HSK-A 63	32	100	24	58
A80.10.16	HSK-A 80	16	60	17	32
A80.10.22	HSK-A 80	22	60	19	40
A80.10.27	HSK-A 80	27	60	21	48
A80.10.32	HSK-A 80	32	60	24	58
A80.10.40	HSK-A 80	40	70	27	70
A100.10.16	HSK-A 100	16	60	17	32
A100.10.22	HSK-A 100	22	60	19	40
A100.10.27	HSK-A 100	27	60	21	48
A100.10.32	HSK-A 100	32	60	24	58
A100.10.40	HSK-A 100	40	70	27	70

Lieferumfang: Mit Fräseranzugsschraube, Mitnehmerring und Passfeder

Delivery: With tightening bolt, driving ring and feather key

Livraison: Avec vis de blocage, bague d'entraînement et clavette

Quernut-Aufsteckfräserdorne DIN 6357 mit vergrößerter Anlagefläche und Kühlkanalbohrungen an der Stirnseite

DIN 69893-1 HSK A

Shell mill holders DIN 6357 with enlarged contact face and coolant exit bores on the end face

Porte-fraises à trou lisse DIN 6357 avec face de contact élargie et conduits pour l'arrosage frontal



Verwendung:

Zur Aufnahme von Messerköpfen und Fräsern mit Quernut.

Application:

For mounting milling cutters with transversal groove.

Application:

Pour le serrage de fraises à rainure transversale.

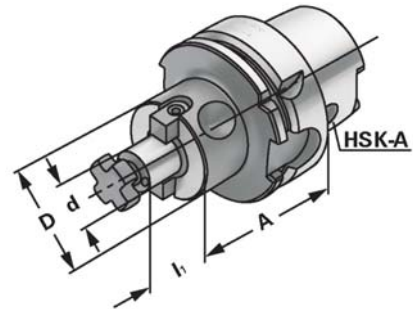

G 6,3 15.000 min⁻¹

≤ 0,004

Bestell-Nr. Order no. Référence	HSK	d _{h6}	A	l ₁	D
A50.11.16	HSK-A 50	16	50	17	38
A50.11.22	HSK-A 50	22	60	19	48
A50.11.27	HSK-A 50	27	60	21	58
A50.11.32	HSK-A 50	32	60	24	78
A63.11.16	HSK-A 63	16	50	17	38
A63.11.22	HSK-A 63	22	50	19	48
A63.11.27	HSK-A 63	27	60	21	58
A63.11.32	HSK-A 63	32	60	24	78
A63.11.40	HSK-A 63	40	60	27	88
A63.11.16.1	HSK-A 63	16	100	17	38
A63.11.22.1	HSK-A 63	22	100	19	48
A63.11.27.1	HSK-A 63	27	100	21	58
A63.11.32.1	HSK-A 63	32	100	24	78
A63.11.40.1	HSK-A 63	40	100	27	88

d = 40: Für große Planfräser mit vier zusätzlichen Gewindebohrungen nach DIN 2079.
For large diameter face mill cutters with four additional threaded holes according to DIN 2079.
Pour fraises à surfacer à grands diamètres avec quatre trous taraudés additionnels suivant DIN 2079.

Lieferumfang: Mit Mitnehmersteinen, Kreuzschraube und Zylinderkopfschraube nach DIN 912 für Fräser mit innerer Kühlmittelzufuhr.

Delivery: With drivers, cross head retaining screw and cylinder head retaining screw for cutters with central coolant.

Livraison: Avec tenons, une vis cruciforme et une vis à tête cylindrique suivant DIN 912 pour fraises avec arrosage central.



Quernut-Aufsteckfräserdorne DIN 6357 mit vergrößerter Anlagefläche und Kühlkanalbohrungen an der Stirnseite

DIN 69893-1 HSK A



Shell mill holders DIN 6357 with enlarged contact face and coolant exit bores on the end face

Porte-fraises à trou lisse DIN 6357 avec face de contact élargie et conduits pour l'arrosage frontal



Verwendung:

Zur Aufnahme von Messerköpfen und Fräsern mit Quernut.

Application:

For mounting milling cutters with transversal groove.

Application:

Pour le serrage de fraises à rainure transversale.

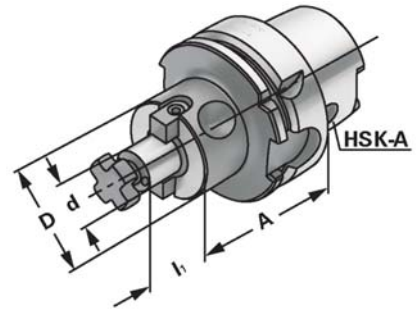

G 6,3 15.000 min⁻¹

≤ 0,004

Bestell-Nr. Order no. Référence	HSK	d _{h6}	A	l ₁	D
A80.11.22	HSK-A 80	22	50	19	48
A80.11.27	HSK-A 80	27	50	21	58
A80.11.32	HSK-A 80	32	60	24	78
A80.11.40	HSK-A 80	40	60	27	88
A100.11.22	HSK-A 100	22	50	19	48
A100.11.27	HSK-A 100	27	50	21	58
A100.11.32	HSK-A 100	32	50	24	78
A100.11.40	HSK-A 100	40	60	27	88
A100.11.60	HSK-A 100	60	70	40	130

d = 40/d = 60: Für große Planfräser mit vier zusätzlichen Gewindebohrungen nach DIN 2079.
For large diameter face mill cutters with four additional threaded holes according to DIN 2079.
Pour fraises à surfer à grands diamètres avec quatre trous taraudés additionnels suivant DIN 2079.

Lieferumfang: Mit Mitnehmersteinen, Kreuzschraube und Zylinderkopfschraube nach DIN 912 für Fräser mit innerer Kühlmittelzufuhr.
Bei d = 60 nur mit vier Befestigungsschrauben nach DIN 912.

Delivery: With drivers, cross head retaining screw and cylinder head retaining screw for cutters with central coolant.
For d = 60 only with four fixation screws according to DIN 912.

Livraison: Avec tenons, une vis cruciforme et une vis à tête cylindrique suivant DIN 912 pour fraises avec arrosage central.
Pour d = 60 seulement avec quatre vis de fixation suivant DIN 912.





Verwendung:

Zur Aufnahme von Werkzeugen mit Morsekegelschaft und Austreibblappen nach DIN 228-1 Form B.

Application:

For mounting tools with Morse taper shank and tang according to DIN 228-1 form B.

Application:

Pour le serrage d'outils avec queue cône Morse et tenon suivant DIN 228-1 forme B.

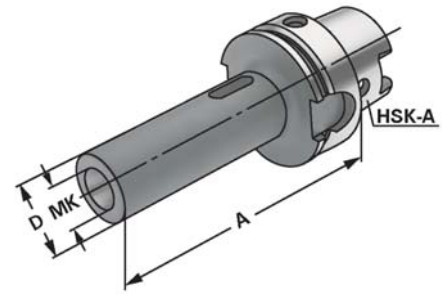

G 6,3 15.000 min⁻¹

≤ 0,005

Bestell-Nr. Order no. Référence	HSK	MK	A	D
A50.07.01	HSK-A 50	1	100	25
A50.07.02	HSK-A 50	2	120	32
A50.07.03	HSK-A 50	3	140	40
A63.07.01	HSK-A 63	1	100	25
A63.07.02	HSK-A 63	2	120	32
A63.07.03	HSK-A 63	3	140	40
A63.07.04	HSK-A 63	4	160	48
A80.07.01	HSK-A 80	1	110	25
A80.07.02	HSK-A 80	2	120	32
A80.07.03	HSK-A 80	3	150	40
A80.07.04	HSK-A 80	4	170	48
A100.07.01	HSK-A 100	1	110	25
A100.07.02	HSK-A 100	2	120	32
A100.07.03	HSK-A 100	3	150	40
A100.07.04	HSK-A 100	4	170	48
A100.07.05	HSK-A 100	5	200	63



Zwischenhülsen für MK mit Anzugsgewinde DIN 6364

Adaptor sleeves for MT with drawbar thread DIN 6364

Douilles de réduction pour CM avec filetage DIN 6364

DIN 69893-1 HSK A



Verwendung:

Zum Spannen von Werkzeugen mit Morsekegelschaft und Anzugsgewinde nach DIN 228-1 Form A.

Application:

For clamping tools with Morse taper shank and thread according to DIN 228-1 form A.

Application:

Pour le serrage d'outils avec queue cône Morse et filetage suivant DIN 228-1 forme A.

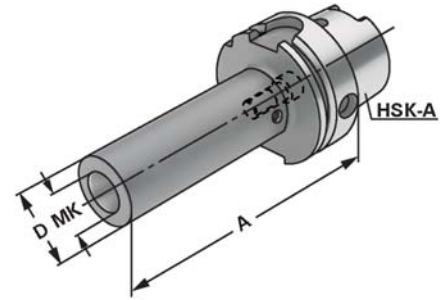

G 6,3 15.000 min⁻¹

≤ 0,005

Bestell-Nr. Order no. Référence	HSK	MK	M	A	D
A50.08.01	HSK-A 50	1	M6	100	25
A50.08.02	HSK-A 50	2	M10	120	32
A50.08.03	HSK-A 50	3	M12	140	40
A63.08.01	HSK-A 63	1	M6	100	25
A63.08.02	HSK-A 63	2	M10	120	32
A63.08.03	HSK-A 63	3	M12	140	40
A63.08.04	HSK-A 63	4	M16	160	48
A80.08.01	HSK-A 80	1	M6	110	25
A80.08.02	HSK-A 80	2	M10	120	32
A80.08.03	HSK-A 80	3	M12	150	40
A80.08.04	HSK-A 80	4	M16	170	48
A100.08.01	HSK-A 100	1	M6	110	25
A100.08.02	HSK-A 100	2	M10	120	32
A100.08.03	HSK-A 100	3	M12	150	40
A100.08.04	HSK-A 100	4	M16	170	48
A100.08.05	HSK-A 100	5	M20	200	63

Lieferumfang: Mit eingebauter Fräseranzugsschraube

Delivery: With built-in tightening bolt

Livraison: Avec vis de serrage montée



4.36

Gewindeschneid-Schnellwechselfutter mit Längen- ausgleich auf Druck und Zug

DIN 69893-1 HSK A

Quick change tapping chucks with length compensation on compression and expansion

Mandrins de taraudage à changement rapide avec compensation longitudinale à la compression et traction



Verwendung:

Zur Aufnahme von Schnellwechsel-Einsätzen für Gewindebohrer.

Application:

For the chucking of quick change adaptors for taps.

Application:

Pour le serrage d'adaptateurs porte-tarands à changement rapide.

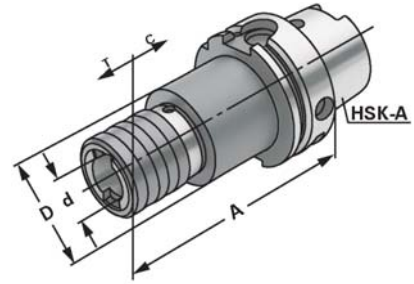

INFO ➔ 10.03

Bestell-Nr. Order no. Référence	HSK	Spannbereich Capacity Capacité	Größe Size Taille	A	D	d	C	T
A50.16.12	HSK-A 50	M3 – M14	1	72	38	19	7	7
A50.16.20	HSK-A 50	M5 – M22	2	110	54	31	12	12
A63.16.12	HSK-A 63	M3 – M14	1	102	38	19	7	7
A63.16.20	HSK-A 63	M5 – M22	2	140	54	31	12	12
A100.16.12	HSK-A 100	M3 – M14	1	112	38	19	7	7
A100.16.20	HSK-A 100	M5 – M22	2	148	54	31	12	12

Hinweis: Für Bearbeitungszentren ohne Synchronspindel.

Note: For machining centres without synchronous spindle.

Observation: Pour centres d'usinage sans broche synchrone.



Gewindeschneid-Schnellwechselfutter ohne Längenausgleich auf Druck und Zug

DIN 69893-1 HSK A



Quick change tapping chucks **without** length compensation on compression and expansion

Mandrins de taraudage à changement rapide **sans** compensation longitudinale à la compression et traction



Verwendung:

Zur Aufnahme von Schnellwechsel-Einsätzen für Gewindebohrer.

Application:

For the chucking of quick change adaptors for taps.

Application:

Pour le serrage d'adaptateurs porte-tarands à changement rapide.

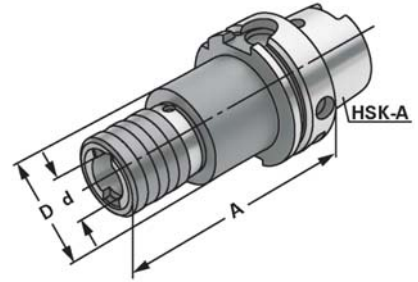

INFO ➔ 10.03

Bestell-Nr. Order no. Référence	HSK	Spannbereich Capacity Capacité	Größe Size Taille	A	D	d
A50.16.12.1	HSK-A 50	M3 – M14	1	65	38	19
A50.16.20.1	HSK-A 50	M5 – M22	2	100	54	31
A63.16.12.1	HSK-A 63	M3 – M14	1	65	38	19
A63.16.20.1	HSK-A 63	M5 – M22	2	100	54	31
A100.16.12.1	HSK-A 100	M3 – M14	1	80	38	19
A100.16.20.1	HSK-A 100	M5 – M22	2	90	54	31

Hinweis: Für Bearbeitungszentren mit Synchronspindel.

Note: For machining centres with synchronous spindle.

Observation: Pour centres d'usinage avec broche synchrone.



CNC-Bohrfutter für Rechts- und Linkslauf

CNC-Drill chucks for clockwise and counter clockwise rotation

Mandrins de perçage CNC pour rotation gauche-droite

DIN 69893-1 HSK A



Verwendung:

Zur Aufnahme von Werkzeugen mit Zylinderschaft.

Application:

For mounting tools with straight shanks.

Application:

Pour le serrage d'outils avec queue cylindrique.

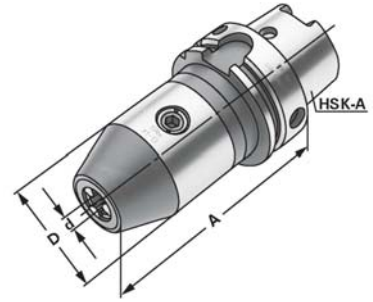

G 6,3 15.000 min⁻¹

≤ 0,03

INFO → 10.03

Bestell-Nr. Order no. Référence	HSK	Spannbereich Capacity Capacité d	A	D
A50.15.13	HSK-A 50	1,0 – 13	116	50
A50.15.16	HSK-A 50	2,5 – 16	116	50
A63.15.13	HSK-A 63	1,0 – 13	104	50
A63.15.16	HSK-A 63	2,5 – 16	109	50
A80.15.13	HSK-A 63	1,0 – 13	109	50
A80.15.16	HSK-A 63	2,5 – 16	114	50
A100.15.13	HSK-A 100	1,0 – 13	107	50
A100.15.16	HSK-A 100	2,5 – 16	112	50

Hinweis: Hohe Präzision und Rundlaufgenauigkeit von ≤ 0,03 mm. Sichere Spannung des Werkzeuges durch mechanische Spannkraftverstärkung. Kein selbständiges Lösen der Spannung während der Bearbeitung bei Links- oder Rechtslauf, sowie bei Spindelstop. Spannen und Lösen mit Sechskantschlüssel.

Note: High precision and accurate concentricity of ≤ 0.03 mm. Secure gripping of the tool through mechanical amplification of the clamping force. No automatic slackening of the clamping force while machining with either clockwise or counter clockwise rotation or on spindle stop. Clamping and releasing effected by means of an Allen wrench.

Observation: Précision élevée et exactitude de circularité de ≤ 0,03 mm. Serrage sûr de l'outil grâce à l'amplification de la force de serrage. Pas de desserrage intempestif en cours d'usinage lors de la rotation la gauche ou la droite, de même qu'en cas d'arrêt de la broche. Serrage et desserrage en utilisant un clé sur à fourche.

Lieferumfang: Mit Spannschlüssel

Delivery: With wrench

Livraison: Avec clé de serrage



Bohrstangenrohlinge

Boring bar blanks
Barres d'alésage

DIN 69893-1 HSK A



Verwendung:
Zur Herstellung von Sonderwerkzeugen.
Application:
For the manufacturing of special tools.
Application:
Pour la fabrication d'outils spéciaux.

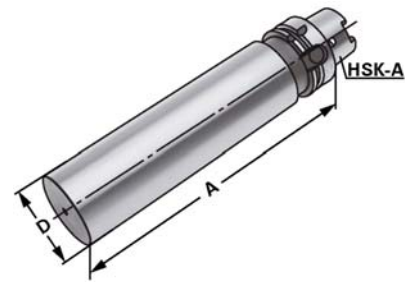

Bestell-Nr. Order no. Référence	HSK	A	D
A32.17.25	HSK-A 32	32,5	100
A40.17.40	HSK-A 40	40,5	160
A50.17.50	HSK-A 50	50,5	200
A63.17.63	HSK-A 63	63,5	250
A80.17.80	HSK-A 80	80,5	250
A100.17.97	HSK-A 100	97,5	250

Ausführung: Steilkegel und Bund gehärtet und geschliffen. Schaft weich zur weiteren Bearbeitung.

Version: Cone and flange hardened and grinded. Soft body for later processing.

Version: Cône et collerette durcis et rectifiés. Corps doux pour un usinage ultérieur.



4.36



Verwendung:

Zur Aufnahme von Werkzeugen mit Zylinderschaft nach DIN 1835 Form A+B+E und DIN 6535 Form HA+HB+HE (größerer Ø 20 mm nur mit Reduzierung).

Application:

For mounting straight-shank tools acc. DIN 1835 form A+B+E and DIN 6535 form HA+HB+HE (larger than dia. 20 mm only with reduction sleeve).

Application:

Pour le serrage d'outils avec queue cylindrique suivant DIN 1835 forme A+B+E et DIN 6535 forme HA+HB+HE (à partir de dia. 20 mm seulement avec réduction).

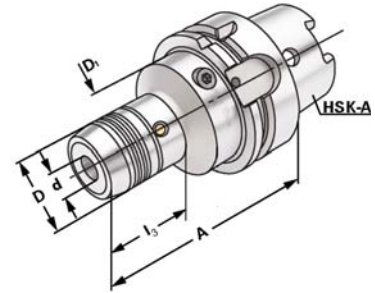

G 6,3 15.000 min⁻¹

≤ 0,003

INFO → 10.03

Bestell-Nr. Order no. Référence	HSK	d	A	D	D ₁	l ₁	l ₂	l ₃
A32.H06	HSK-A 32	6	80	26	26	37	10	20
A32.H08	HSK-A 32	8	80	28	26	37	10	35
A32.H10	HSK-A 32	10	85	30	26	42	10	35
A32.H12	HSK-A 32	12	90	32	26	47	10	35
A32.H16	HSK-A 32	16	100	38	26	52	10	45
<hr/>								
A40.H06	HSK-A 40	6	80	26	34	37	10	45
A40.H08	HSK-A 40	8	80	28	34	37	10	44
A40.H10	HSK-A 40	10	85	30	34	42	10	44
A40.H12	HSK-A 40	12	90	32	34	47	10	43
A40.H14	HSK-A 40	14	90	34	34	47	10	41
A40.H16	HSK-A 40	16	90	38	34	52	10	38
A40.H18	HSK-A 40	18	90	40	34	52	10	38
A40.H20	HSK-A 40	20	90	42	34	52	10	16
<hr/>								
A50.H06	HSK-A 50	6	80	26	42	37	10	45
A50.H08	HSK-A 50	8	80	28	42	37	10	44
A50.H10	HSK-A 50	10	85	30	42	42	10	44
A50.H12	HSK-A 50	12	90	32	42	47	10	43
A50.H14	HSK-A 50	14	90	34	42	47	10	41
A50.H16	HSK-A 50	16	95	38	42	52	10	43
A50.H18	HSK-A 50	18	95	40	42	52	10	43
A50.H20	HSK-A 50	20	100	42	42	52	10	26

Lieferumfang: Mit Spannschlüssel

Delivery: With wrench

Livraison: Avec clé de serrage

l₁ = max. Einstecktiefe

l₁ = max. clamping depth

l₁ = max. profondeur d'insertion

l₂ = max. Verstellweg

l₂ = max. length adjustment range

l₂ = max. course de réglage



Hydro-Dehnspannfutter

Hydraulic expansion chucks

Mandrins expansibles hydrauliques

DIN 69893-1 HSK A



Verwendung:

Zur Aufnahme von Werkzeugen mit Zylinderschaft nach DIN 1835 Form A+B+E und DIN 6535 Form HA+HB+HE (größer Ø 20 mm nur mit Reduzierung).

Application:

For mounting straight-shank tools acc. DIN 1835 form A+B+E and DIN 6535 form HA+HB+HE (larger than dia. 20 mm only with reduction sleeve).

Application:

Pour le serrage d'outils avec queue cylindrique suivant DIN 1835 forme A+B+E et DIN 6535 forme HA+HB+HE (à partir de dia. 20 mm seulement avec réduction).

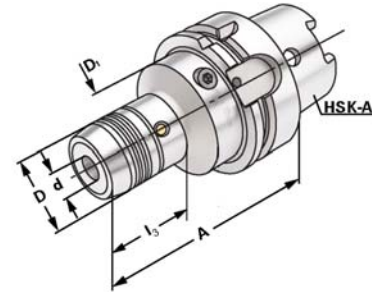

G 6,3 15.000 min⁻¹

≤ 0,003

INFO → 10.03

Bestell-Nr. Order no. Référence	HSK	d	A	D	D ₁	l ₁	l ₂	l ₃
A63.H06	HSK-A 63	6	80	26	50	37	10	47
A63.H08	HSK-A 63	8	80	28	50	37	10	47
A63.H10	HSK-A 63	10	85	30	50	42	10	46
A63.H12	HSK-A 63	12	90	32	50	47	10	46
A63.H14	HSK-A 63	14	90	34	50	47	10	44
A63.H16	HSK-A 63	16	95	38	50	52	10	43
A63.H18	HSK-A 63	18	95	40	50	52	10	43
A63.H20	HSK-A 63	20	100	42	50	52	10	42
A63.H25	HSK-A 63	25	120	50	50	58	10	26
A63.H32	HSK-A 63	32	125	60	50	62	10	42
A63.H06.1	HSK-A 63	6	150	26	50	37	10	47
A63.H08.1	HSK-A 63	8	150	28	50	37	10	46
A63.H10.1	HSK-A 63	10	150	30	50	42	10	46
A63.H12.1	HSK-A 63	12	150	32	50	47	10	45
A63.H14.1	HSK-A 63	14	150	34	50	47	10	45
A63.H16.1	HSK-A 63	16	150	38	50	52	10	43,5
A63.H18.1	HSK-A 63	18	150	40	50	52	10	43
A63.H20.1	HSK-A 63	20	150	42	50	52	10	42
A63.H25.1	HSK-A 63	25	150	50	50	58	10	-
A63.H06.2	HSK-A 63	6	200	26	50	37	10	47
A63.H08.2	HSK-A 63	8	200	28	50	37	10	46
A63.H10.2	HSK-A 63	10	200	30	50	42	10	46
A63.H12.2	HSK-A 63	12	200	32	50	47	10	45
A63.H14.2	HSK-A 63	14	200	34	50	47	10	45
A63.H16.2	HSK-A 63	16	200	38	50	52	10	43,5
A63.H18.2	HSK-A 63	18	200	40	50	52	10	43
A63.H20.2	HSK-A 63	20	200	42	50	52	10	42
A63.H25.2	HSK-A 63	25	200	50	50	58	10	-

Lieferumfang: Mit Spannschlüssel

Delivery: With wrench

Livraison: Avec clé de serrage

l₁ = max. Einstecktiefe

l₁ = max. clamping depth

l₁ = max. profondeur d'insertion

l₂ = max. Verstellweg

l₂ = max. length adjustment range

l₂ = max. course de réglage





Verwendung:

Zur Aufnahme von Werkzeugen mit Zylinderschaft nach DIN 1835 Form A+B+E und DIN 6535 Form HA+HB+HE (größer Ø 20 mm nur mit Reduzierung).

Application:

For mounting straight-shank tools acc. DIN 1835 form A+B+E and DIN 6535 form HA+HB+HE (larger than dia. 20 mm only with reduction sleeve).

Application:

Pour le serrage d'outils avec queue cylindrique suivant DIN 1835 forme A+B+E et DIN 6535 forme HA+HB+HE (à partir de dia. 20 mm seulement avec réduction).

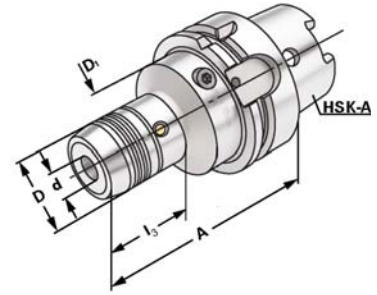

G 6,3 15.000 min⁻¹

≤ 0,003

INFO → 10.03

Bestell-Nr. Order no. Référence	HSK	d	A	D	D ₁	l ₁	l ₂	l ₃
A80.H06	HSK-A 80	6	85	26	56	37	10	54
A80.H08	HSK-A 80	8	85	28	56	37	10	53
A80.H10	HSK-A 80	10	90	30	56	42	10	53
A80.H12	HSK-A 80	12	95	32	56	47	10	52
A80.H14	HSK-A 80	14	95	34	56	47	10	51
A80.H16	HSK-A 80	16	100	38	56	52	10	50
A80.H18	HSK-A 80	18	100	40	56	52	10	50
A80.H20	HSK-A 80	20	105	42	56	52	10	49
A80.H25	HSK-A 80	25	115	50	56	58	10	62
A80.H32	HSK-A 80	32	120	60	56	62	10	26
A100.H06	HSK-A 100	6	85	26	63	37	10	56
A100.H08	HSK-A 100	8	85	28	63	37	10	56
A100.H10	HSK-A 100	10	90	30	63	42	10	55
A100.H12	HSK-A 100	12	95	32	63	47	10	55
A100.H14	HSK-A 100	14	95	34	63	47	10	53
A100.H16	HSK-A 100	16	100	38	63	52	10	53
A100.H18	HSK-A 100	18	100	40	63	52	10	52
A100.H20	HSK-A 100	20	105	42	63	52	10	51
A100.H25	HSK-A 100	25	115	50	63	58	10	64
A100.H32	HSK-A 100	32	120	60	63	62	10	61
A100.H06.1	HSK-A 100	6	150	26	50	37	10	56
A100.H08.1	HSK-A 100	8	150	28	50	37	10	55,5
A100.H10.1	HSK-A 100	10	150	30	50	42	10	55
A100.H12.1	HSK-A 100	12	150	32	50	47	10	54,5
A100.H14.1	HSK-A 100	14	150	34	50	47	10	53
A100.H16.1	HSK-A 100	16	150	38	50	52	10	52,5
A100.H18.1	HSK-A 100	18	150	40	50	52	10	52
A100.H20.1	HSK-A 100	20	150	42	50	52	10	51
A100.H25.1	HSK-A 100	25	150	50	50	58	10	-
A100.H32.1	HSK-A 100	32	150	60	60	62	10	-

Lieferumfang: Mit Spannschlüssel
Delivery: With wrench
Livraison: Avec clé de serrage

l₁ = max. Einstecktiefe
 l₁ = max. clamping depth
 l₁ = max. profondeur d'insertion

l₂ = max. Verstellweg
 l₂ = max. length adjustment range
 l₂ = max. course de réglage



Hydro-Dehnspannfutter

Hydraulic expansion chucks

Mandrins expansibles hydrauliques

DIN 69893-1 HSK A



Verwendung:

Zur Aufnahme von Werkzeugen mit Zylinderschaft nach DIN 1835 Form A+B+E und DIN 6535 Form HA+HB+HE (größerer Ø 20 mm nur mit Reduzierung).

Application:

For mounting straight-shank tools acc. DIN 1835 form A+B+E and DIN 6535 form HA+HB+HE (larger than dia. 20 mm only with reduction sleeve).

Application:

Pour le serrage d'outils avec queue cylindrique suivant DIN 1835 forme A+B+E et DIN 6535 forme HA+HB+HE (à partir de dia. 20 mm seulement avec réduction).

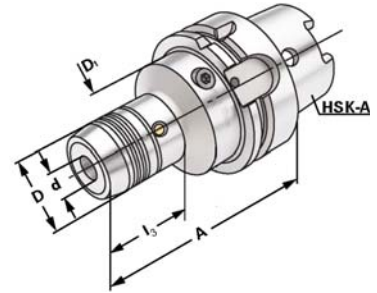

G 6,3 15.000 min⁻¹

≤ 0,003

INFO ➔ 10.03

Bestell-Nr. Order no. Référence	HSK	d	A	D	D ₁	l ₁	l ₂	l ₃
A100.H06.2	HSK-A 100	6	200	26	50	37	10	56
A100.H08.2	HSK-A 100	8	200	28	50	37	10	55,5
A100.H10.2	HSK-A 100	10	200	30	50	42	10	55
A100.H12.2	HSK-A 100	12	200	32	50	47	10	54,5
A100.H14.2	HSK-A 100	14	200	34	50	47	10	53
A100.H16.2	HSK-A 100	16	200	38	50	52	10	52,5
A100.H18.2	HSK-A 100	18	200	40	50	52	10	52
A100.H20.2	HSK-A 100	20	200	42	50	52	10	51
A100.H25.2	HSK-A 100	25	200	50	50	58	10	–
A100.H32.2	HSK-A 100	32	200	60	60	62	10	–

Lieferumfang: Mit Spannschlüssel

Delivery: With wrench

Livraison: Avec clé de serrage

l₁ = max. Einstecktiefe

l₁ = max. clamping depth

l₁ = max. profondeur d'insertion

l₂ = max. Verstellweg

l₂ = max. length adjustment range

l₂ = max. course de réglage



Schrumpffutter zum Spannen von HM und HSS Werkzeugschäften

DIN 69893-1 HSK A

Shrink chucks for mounting of solid carbide and HSS-tool shanks

Mandrins de frettage pour le serrage de queues d'outils carbures de type HM et HSS



Verwendung:

Zur Aufnahme von Werkzeugen mit Zylinderschaft.

Application:

For mounting straight-shank tools.

Application:

Pour le serrage d'outils avec queue cylindrique.

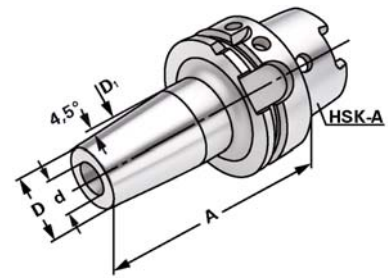

G 6,3 15.000 min⁻¹

≤ 0,003

Bestell-Nr. Order no. Référence	HSK	d	A	D	D ₁	l ₁	l ₂
A32.70.03	HSK-A 32	3	60	11	15	10	-
A32.70.04	HSK-A 32	4	60	14	15	20	5
A32.70.05	HSK-A 32	5	60	16	15	20	5
A32.70.06	HSK-A 32	6	70	21	27	36	10
A32.70.08	HSK-A 32	8	70	21	27	36	10
A32.70.10	HSK-A 32	10	70	24	29	42	10
A32.70.12	HSK-A 32	12	90	24	29	47	10
A32.70.14	HSK-A 32	14	90	27	34	47	10
A32.70.16	HSK-A 32	16	90	27	34	50	10
A32.70.20	HSK-A 32	20	100	33	40	52	10
A40.70.03	HSK-A 40	3	80	11	15	10	-
A40.70.04	HSK-A 40	4	80	14	22	20	5
A40.70.05	HSK-A 40	5	80	16	22	20	5
A40.70.06	HSK-A 40	6	80	21	27	36	10
A40.70.08	HSK-A 40	8	80	21	27	36	10
A40.70.10	HSK-A 40	10	80	24	32	42	10
A40.70.12	HSK-A 40	12	90	24	32	47	10
A40.70.14	HSK-A 40	14	90	27	34	47	10
A40.70.16	HSK-A 40	16	90	27	34	50	10
A40.70.18	HSK-A 40	18	95	33	42	50	10
A40.70.20	HSK-A 40	20	100	33	42	52	10
A40.70.25	HSK-A 40	25	100	44	51	58	10

Für Ø 3, 4 und 5 mm nur Hartmetallschäfte verwenden!

For Ø 3, 4 and 5 mm only solid carbide tool shanks must be used!

Pour Ø 3, 4 et 5 mm il faut seulement utiliser de queues d'outils carbures de type HM!

Hinweis: Aufnahme für Induktiv-, Kontakt- und Heißluftschumpfgeräte geeignet. Schafttoleranz bei Ø 3, 4 und 5 mm = h₄, bei Ø 6–Ø 32 mm = h₆

Note: Toolholders suitable for induction-, contact- and hot air shrink units. Ø 3, 4, 5 with h₄-tolerance and Ø 6–Ø 32 with h₆-tolerance

Observation: Porte-outils convenables pour machines à frotter par induction-, par contact-, ou par air chaud. Ø 3, 4, 5 avec h₄-tolerance et Ø 6–Ø 32 avec h₆-tolerance

l₁ = max. Einstecktiefe

l₁ = max. clamping depth

l₁ = max. profondeur d'insertion

l₂ = max. Verstellweg

l₂ = max. length adjustment range

l₂ = max. course de réglage



Schrumpffutter zum Spannen von HM und HSS Werkzeugschäften

DIN 69893-1 HSK A



Shrink chucks for mounting of solid carbide and HSS-tool shanks

Mandrins de frettage pour le serrage de queues d'outils carbures de type HM et HSS



Verwendung:

Zur Aufnahme von Werkzeugen mit Zylinderschaft.

Application:

For mounting straight-shank tools.

Application:

Pour le serrage d'outils avec queue cylindrique.

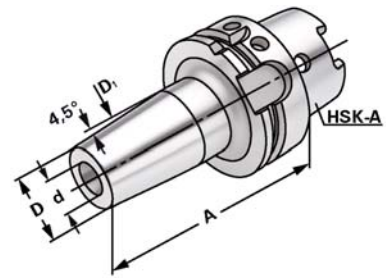

G 6,3 15.000 min⁻¹

≤ 0,003

Bestell-Nr. Order no. Référence	HSK	d	A	D	D ₁	l ₁	l ₂
A50.70.03	HSK-A 50	3	80	11	15	10	–
A50.70.04	HSK-A 50	4	80	14	22	20	5
A50.70.05	HSK-A 50	5	80	16	22	20	5
A50.70.06	HSK-A 50	6	80	21	27	36	10
A50.70.08	HSK-A 50	8	80	21	27	36	10
A50.70.10	HSK-A 50	10	85	24	32	42	10
A50.70.12	HSK-A 50	12	90	24	32	47	10
A50.70.14	HSK-A 50	14	90	27	34	47	10
A50.70.16	HSK-A 50	16	95	27	34	50	10
A50.70.18	HSK-A 50	18	95	33	42	50	10
A50.70.20	HSK-A 50	20	100	33	42	52	10
A50.70.25	HSK-A 50	25	115	44	53	58	10
A50.70.32	HSK-A 50	32	120	44	53	62	10
A50.70.06.1	HSK-A 50	6	120	21	27	20	10
A50.70.08.1	HSK-A 50	8	120	21	27	20	10
A50.70.10.1	HSK-A 50	10	120	24	32	36	10
A50.70.12.1	HSK-A 50	12	120	24	32	36	10
A50.70.14.1	HSK-A 50	14	120	27	34	41	10
A50.70.16.1	HSK-A 50	16	120	27	34	47	10
A50.70.18.1	HSK-A 50	18	120	33	42	47	10
A50.70.20.1	HSK-A 50	20	120	33	42	50	10
A50.70.03.2	HSK-A 50	3	160	11	15	10	–
A50.70.04.2	HSK-A 50	4	160	14	22	20	5
A50.70.05.2	HSK-A 50	5	160	16	22	20	5
A50.70.06.2	HSK-A 50	6	160	21	27	36	10
A50.70.08.2	HSK-A 50	8	160	21	27	36	10
A50.70.10.2	HSK-A 50	10	160	24	32	41	10
A50.70.12.2	HSK-A 50	12	160	24	32	47	10
A50.70.14.2	HSK-A 50	14	160	27	34	47	10
A50.70.16.2	HSK-A 50	16	160	27	34	50	10
A50.70.18.2	HSK-A 50	18	160	33	42	50	10
A50.70.20.2	HSK-A 50	20	160	33	42	52	10

Hinweis: Aufnahme für Induktiv-, Kontakt- und Heißluftschumpfgeräte geeignet. Schafttoleranz bei Ø 3, 4 und 5 mm = h₄, bei Ø 6–Ø 32 mm = h₆

Note: Toolholders suitable for induction-, contact- and hot air shrink units. Ø 3, 4, 5 with h₄-tolerance and Ø 6–Ø 32 with h₆-tolerance

Observation: Porte-outils convenables pour machines à fretter par induction-, par contact-, ou par air chaud. Ø 3, 4, 5 avec h₄-tolerance et Ø 6–Ø 32 avec h₆-tolerance

l₁ = max. Einstecktiefe

l₁ = max. clamping depth

l₁ = max. profondeur d'insertion

l₂ = max. Verstellweg

l₂ = max. length adjustment range

l₂ = max. course de réglage

Schrumpffutter zum Spannen von HM und HSS Werkzeugschäften

DIN 69893-1 HSK A

Shrink chucks for mounting of solid carbide and HSS-tool shanks

Mandrins de frettage pour le serrage de queues d'outils carbures de type HM et HSS



Verwendung:

Zur Aufnahme von Werkzeugen mit Zylinderschaft.

Application:

For mounting straight-shank tools.

Application:

Pour le serrage d'outils avec queue cylindrique.

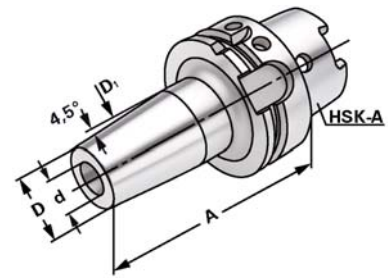

G 6,3 15.000 min⁻¹

≤ 0,003

Bestell-Nr. Order no. Référence	HSK	d	A	D	D ₁	l ₁	l ₂
A63.70.03	HSK-A 63	3	80	11	15	10	-
A63.70.04	HSK-A 63	4	80	14	22	20	5
A63.70.05	HSK-A 63	5	80	16	22	20	5
A63.70.06	HSK-A 63	6	80	21	27	36	10
A63.70.08	HSK-A 63	8	80	21	27	36	10
A63.70.10	HSK-A 63	10	85	24	32	42	10
A63.70.12	HSK-A 63	12	90	24	32	47	10
A63.70.14	HSK-A 63	14	90	27	34	47	10
A63.70.16	HSK-A 63	16	95	27	34	50	10
A63.70.18	HSK-A 63	18	95	33	42	50	10
A63.70.20	HSK-A 63	20	100	33	42	52	10
A63.70.25	HSK-A 63	25	115	44	53	58	10
A63.70.32	HSK-A 63	32	120	44	53	61	10
A63.70.03.1	HSK-A 63	3	120	11	15	10	-
A63.70.04.1	HSK-A 63	4	120	14	22	20	5
A63.70.05.1	HSK-A 63	5	120	16	22	20	5
A63.70.06.1	HSK-A 63	6	120	21	27	20	10
A63.70.08.1	HSK-A 63	8	120	21	27	20	10
A63.70.10.1	HSK-A 63	10	120	24	32	36	10
A63.70.12.1	HSK-A 63	12	120	24	32	36	10
A63.70.14.1	HSK-A 63	14	120	27	34	41	10
A63.70.16.1	HSK-A 63	16	120	27	34	47	10
A63.70.18.1	HSK-A 63	18	120	33	42	47	10
A63.70.20.1	HSK-A 63	20	120	33	42	50	10
A63.70.25.1	HSK-A 63	25	120	44	53	58	10

Für Ø 3, 4 und 5 mm nur Hartmetallschäfte verwenden!

For Ø 3, 4 and 5 mm only solid carbide tool shanks must be used!

Pour Ø 3, 4 et 5 mm il faut seulement utiliser de queues d'outils carbures de type HM!

Hinweis: Aufnahme für Induktiv-, Kontakt- und Heißluftschumpfgeräte geeignet.
Schafttoleranz bei Ø 3, 4 und 5 mm = h₄, bei Ø 6–Ø 32 mm = h₆

Note: Toolholders suitable for induction-, contact- and hot air shrink units.
Ø 3, 4, 5 with h₄-tolerance and Ø 6–Ø 32 with h₆-tolerance

Observation: Porte-outils convenables pour machines à fretter par induction-,
par contact-, ou par air chaud.
Ø 3, 4, 5 avec h₄-tolerance et Ø 6–Ø 32 avec h₆-tolerance

l₁ = max. Einstecktiefe

l₁ = max. clamping depth

l₁ = max. profondeur d'insertion

l₂ = max. Verstellweg

l₂ = max. length adjustment range

l₂ = max. course de réglage



Schrumpffutter zum Spannen von HM und HSS Werkzeugschäften

DIN 69893-1 HSK A



Shrink chucks for mounting of solid carbide and HSS-tool shanks

Mandrins de frettage pour le serrage de queues d'outils carbures de type HM et HSS



Verwendung:

Zur Aufnahme von Werkzeugen mit Zylinderschaft.

Application:

For mounting straight-shank tools.

Application:

Pour le serrage d'outils avec queue cylindrique.

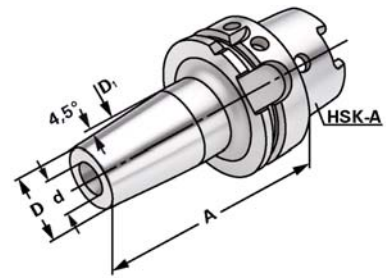

G 6,3 15.000 min⁻¹

≤ 0,003

Bestell-Nr. Order no. Référence	HSK	d	A	D	D ₁	l ₁	l ₂
A63.70.03.2	HSK-A 63	3	160	11	15	10	-
A63.70.04.2	HSK-A 63	4	160	14	22	20	5
A63.70.05.2	HSK-A 63	5	160	16	22	20	5
A63.70.06.2	HSK-A 63	6	160	21	27	36	10
A63.70.08.2	HSK-A 63	8	160	21	27	36	10
A63.70.10.2	HSK-A 63	10	160	24	32	41	10
A63.70.12.2	HSK-A 63	12	160	24	32	47	10
A63.70.14.2	HSK-A 63	14	160	27	34	47	10
A63.70.16.2	HSK-A 63	16	160	27	34	50	10
A63.70.18.2	HSK-A 63	18	160	33	42	50	10
A63.70.20.2	HSK-A 63	20	160	33	42	52	10
A63.70.25.2	HSK-A 63	25	160	44	53	58	10
A63.70.32.2	HSK-A 63	32	160	44	53	62	10
A63.70.06.3	HSK-A 63	6	200	21	27	36	10
A63.70.08.3	HSK-A 63	8	200	21	27	36	10
A63.70.10.3	HSK-A 63	10	200	24	32	41	10
A63.70.12.3	HSK-A 63	12	200	24	32	47	10
A63.70.16.3	HSK-A 63	16	200	27	34	50	10
A63.70.20.3	HSK-A 63	20	200	33	42	52	10
A63.70.32.3	HSK-A 63	32	200	44	53	62	10

Für Ø 3, 4 und 5 mm nur Hartmetallschäfte verwenden!

For Ø 3, 4 and 5 mm only solid carbide tool shanks must be used!

Pour Ø 3, 4 et 5 mm il faut seulement utiliser de queues d'outils carbures de type HM!

Hinweis: Aufnahme für Induktiv-, Kontakt- und Heißluftschumpfgeräte geeignet.
Schafttoleranz bei Ø 3, 4 und 5 mm = h₄, bei Ø 6–Ø 32 mm = h₆

Note: Toolholders suitable for induction-, contact- and hot air shrink units.
Ø 3, 4, 5 with h₄-tolerance and Ø 6–Ø 32 with h₆-tolerance

Observation: Porte-outils convenables pour machines à fretter par induction-,
par contact-, ou par air chaud.
Ø 3, 4, 5 avec h₄-tolerance et Ø 6–Ø 32 avec h₆-tolerance

l₁ = max. Einstecktiefe

l₁ = max. clamping depth

l₁ = max. profondeur d'insertion

l₂ = max. Verstellweg

l₂ = max. length adjustment range

l₂ = max. course de réglage



Schrumpffutter zum Spannen von HM und HSS Werkzeugschäften

DIN 69893-1 HSK A

Shrink chucks for mounting of solid carbide and HSS-tool shanks

Mandrins de frettage pour le serrage de queues d'outils carbures de type HM et HSS



Verwendung:

Zur Aufnahme von Werkzeugen mit Zylinderschaft.

Application:

For mounting straight-shank tools.

Application:

Pour le serrage d'outils avec queue cylindrique.

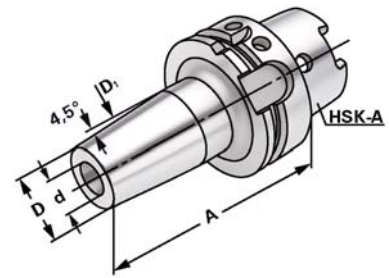

G 6,3 15.000 min⁻¹

≤ 0,003

Bestell-Nr. Order no. Référence	HSK	d	A	D	D ₁	l ₁	l ₂
A80.70.04	HSK-A 80	4	80	14	22	20	5
A80.70.06	HSK-A 80	6	85	21	27	36	10
A80.70.08	HSK-A 80	8	85	21	27	36	10
A80.70.10	HSK-A 80	10	90	24	32	42	10
A80.70.12	HSK-A 80	12	95	24	32	47	10
A80.70.14	HSK-A 80	14	95	27	34	47	10
A80.70.16	HSK-A 80	16	100	27	34	50	10
A80.70.18	HSK-A 80	18	100	33	42	50	10
A80.70.20	HSK-A 80	20	105	33	42	52	10
A80.70.25	HSK-A 80	25	115	44	53	58	10
A80.70.32	HSK-A 80	32	120	44	53	61	10
A80.70.06.1	HSK-A 80	6	120	21	27	36	10
A80.70.08.1	HSK-A 80	8	120	21	27	36	10
A80.70.10.1	HSK-A 80	10	120	24	32	41	10
A80.70.12.1	HSK-A 80	12	120	24	32	47	10
A80.70.14.1	HSK-A 80	14	120	27	34	47	10
A80.70.06.2	HSK-A 80	6	160	21	27	36	10
A80.70.08.2	HSK-A 80	8	160	21	27	36	10
A80.70.10.2	HSK-A 80	10	160	24	32	41	10
A80.70.12.2	HSK-A 80	12	160	24	32	47	10
A80.70.14.2	HSK-A 80	14	160	27	34	47	10
A80.70.16.2	HSK-A 80	16	160	27	34	50	10
A80.70.18.2	HSK-A 80	18	160	33	42	50	10
A80.70.20.2	HSK-A 80	20	160	33	42	52	10
A80.70.25.2	HSK-A 80	25	160	44	53	58	10

Für Ø 3, 4 und 5 mm nur Hartmetallschäfte verwenden!

For Ø 3, 4 and 5 mm only solid carbide tool shanks must be used!

Pour Ø 3, 4 et 5 mm il faut seulement utiliser de queues d'outils carbures de type HM!

Hinweis: Aufnahme für Induktiv-, Kontakt- und Heißluftschumpfgeräte geeignet.
Schafttoleranz bei Ø 3, 4 und 5 mm = h₄, bei Ø 6–Ø 32 mm = h₆

Note: Toolholders suitable for induction-, contact- and hot air shrink units.
Ø 3, 4, 5 with h₄-tolerance and Ø 6–Ø 32 with h₆-tolerance

Observation: Porte-outils convenables pour machines à fretter par induction-,
par contact-, ou par air chaud.
Ø 3, 4, 5 avec h₄-tolerance et Ø 6–Ø 32 avec h₆-tolerance

l₁ = max. Einstecktiefe

l₁ = max. clamping depth

l₁ = max. profondeur d'insertion

l₂ = max. Verstellweg

l₂ = max. length adjustment range

l₂ = max. course de réglage



Schrumpffutter zum Spannen von HM und HSS Werkzeugschäften

DIN 69893-1 HSK A



Shrink chucks for mounting of solid carbide and HSS-tool shanks

Mandrins de frettage pour le serrage de queues d'outils carbures de type HM et HSS



Verwendung:

Zur Aufnahme von Werkzeugen mit Zylinderschaft.

Application:

For mounting straight-shank tools.

Application:

Pour le serrage d'outils avec queue cylindrique.

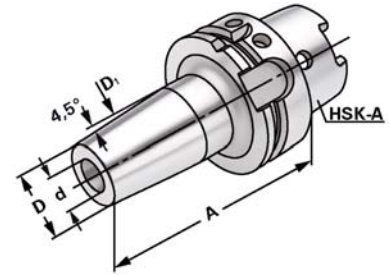

G 6,3 15.000 min⁻¹

≤ 0,003

Bestell-Nr. Order no. Référence	HSK	d	A	D	D ₁	l ₁	l ₂
A100.70.04	HSK-A 100	4	85	14	22	20	5
A100.70.05	HSK-A 100	5	85	16	22	20	5
A100.70.06	HSK-A 100	6	85	21	27	36	10
A100.70.08	HSK-A 100	8	85	21	27	36	10
A100.70.10	HSK-A 100	10	90	24	32	42	10
A100.70.12	HSK-A 100	12	95	24	32	47	10
A100.70.14	HSK-A 100	14	95	27	34	47	10
A100.70.16	HSK-A 100	16	100	27	34	50	10
A100.70.18	HSK-A 100	18	100	33	42	50	10
A100.70.20	HSK-A 100	20	105	33	42	52	10
A100.70.25	HSK-A 100	25	120	44	53	56	10
A100.70.32	HSK-A 100	32	120	44	53	62	10
A100.70.40	HSK-A 100	40	150	78	90	90	10
A100.70.50	HSK-A 100	50	150	78	90	90	10
A100.70.06.1	HSK-A 100	6	120	21	27	36	10
A100.70.08.1	HSK-A 100	8	120	21	27	36	10
A100.70.10.1	HSK-A 100	10	120	24	32	41	10
A100.70.12.1	HSK-A 100	12	120	24	32	47	10
A100.70.14.1	HSK-A 100	14	120	27	34	47	10
A100.70.16.1	HSK-A 100	16	120	27	34	50	10
A100.70.18.1	HSK-A 100	18	120	33	42	50	10
A100.70.20.1	HSK-A 100	20	120	33	42	52	10
A100.70.06.2	HSK-A 100	6	160	21	27	36	10
A100.70.08.2	HSK-A 100	8	160	21	27	36	10
A100.70.10.2	HSK-A 100	10	160	24	32	41	10
A100.70.12.2	HSK-A 100	12	160	24	32	47	10
A100.70.14.2	HSK-A 100	14	160	27	34	47	10
A100.70.16.2	HSK-A 100	16	160	27	34	50	10
A100.70.18.2	HSK-A 100	18	160	33	42	50	10
A100.70.20.2	HSK-A 100	20	160	33	42	52	10
A100.70.25.2	HSK-A 100	25	160	44	53	58	10
A100.70.32.2	HSK-A 100	32	160	44	53	62	10

Hinweis: Aufnahme für Induktiv-, Kontakt- und Heißluftschumpfgeräte geeignet. Schafttoleranz bei Ø 3, 4 und 5 mm = h₄, bei Ø 6–Ø 32 mm = h₆

Note: Toolholders suitable for induction-, contact- and hot air shrink units. Ø 3, 4, 5 with h₄-tolerance and Ø 6–Ø 32 with h₆-tolerance

Observation: Porte-outils convenables pour machines à fretter par induction-, par contact-, ou par air chaud. Ø 3, 4, 5 avec h₄-tolerance et Ø 6–Ø 32 avec h₆-tolerance

l₁ = max. Einstecktiefe

l₁ = max. clamping depth

l₁ = max. profondeur d'insertion

l₂ = max. Verstellweg

l₂ = max. length adjustment range

l₂ = max. course de réglage

Schrumpffutter zum Spannen von HM und HSS Werkzeugschäften

DIN 69893-1 HSK A

Shrink chucks for mounting of solid carbide and HSS-tool shanks

Mandrins de frettage pour le serrage de queues d'outils carbures de type HM et HSS



Verwendung:

Zur Aufnahme von Werkzeugen mit Zylinderschaft.

Application:

For mounting straight-shank tools.

Application:

Pour le serrage d'outils avec queue cylindrique.

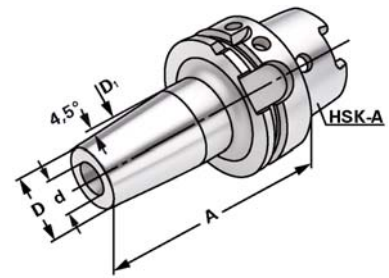

G 6,3 15.000 min⁻¹

≤ 0,003

Bestell-Nr. Order no. Référence	HSK	d	A	D	D ₁	l ₁	l ₂
A100.70.06.3	HSK-A 100	6	200	21	27	36	10
A100.70.08.3	HSK-A 100	8	200	21	27	36	10
A100.70.10.3	HSK-A 100	10	200	24	32	41	10
A100.70.12.3	HSK-A 100	12	200	24	32	47	10
A100.70.14.3	HSK-A 100	14	200	27	34	47	10
A100.70.16.3	HSK-A 100	16	200	27	34	50	10
A100.70.18.3	HSK-A 100	18	200	33	42	50	10
A100.70.20.3	HSK-A 100	20	200	33	42	52	10
A100.70.25.3	HSK-A 100	25	200	44	53	58	10
A100.70.32.3	HSK-A 100	32	200	44	53	62	10
A100.70.06.4	HSK-A 100	6	250	21	27	36	10
A100.70.08.4	HSK-A 100	8	250	21	27	36	10
A100.70.10.4	HSK-A 100	10	250	24	32	41	10
A100.70.12.4	HSK-A 100	12	250	24	32	47	10
A100.70.14.4	HSK-A 100	14	250	27	34	47	10
A100.70.16.4	HSK-A 100	16	250	27	34	50	10

Hinweis: Aufnahme für Induktiv-, Kontakt- und Heißluftschumpfgeräte geeignet.
Schafttoleranz bei Ø 6–Ø 32 mm = h₆

Note: Toolholders suitable for induction-, contact- and hot air shrink units.
Ø 6–Ø 32 with h₆-tolerance

Observation: Porte-outils convenables pour machines à fretter par induction-,
par contact-, ou par air chaud.
Ø 6–Ø 32 avec h₆-tolerance

l₁ = max. Einstecktiefe

l₁ = max. clamping depth

l₁ = max. profondeur d'insertion

l₂ = max. Verstellweg

l₂ = max. length adjustment range

l₂ = max. course de réglage



Schrumpffutter mit Kühlkanälen zum Spannen von HM und HSS Werkzeugschäften

DIN 69893-1 HSK A



Shrink chucks for mounting of solid carbide and HSS-tool shanks

Mandrins de frettage pour le serrage de queues d'outils carbures de type HM et HSS



Verwendung:

Zur Aufnahme von Werkzeugen mit Zylinderschaft.

Application:

For mounting straight-shank tools.

Application:

Pour le serrage d'outils avec queue cylindrique.

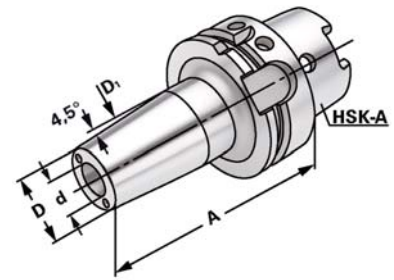

G 6,3 15.000 min⁻¹

≤ 0,003

Bestell-Nr. Order no. Référence	HSK	d	A	D	D ₁	l ₁	l ₂
A63.70.03.K	HSK-A 63	3	80	11	15	10	–
A63.70.04.K	HSK-A 63	4	80	14	22	20	5
A63.70.05.K	HSK-A 63	5	80	16	22	20	5
A63.70.06.K	HSK-A 63	6	80	21	27	36	10
A63.70.08.K	HSK-A 63	8	80	21	27	36	10
A63.70.10.K	HSK-A 63	10	85	24	32	42	10
A63.70.12.K	HSK-A 63	12	90	24	32	47	10
A63.70.14.K	HSK-A 63	14	90	27	34	47	10
A63.70.16.K	HSK-A 63	16	95	27	34	50	10
A63.70.18.K	HSK-A 63	18	95	33	42	50	10
A63.70.20.K	HSK-A 63	20	100	33	42	52	10
A63.70.25.K	HSK-A 63	25	115	44	53	58	10
A63.70.32.K	HSK-A 63	32	120	44	53	61	10
A63.70.03.1.K	HSK-A 63	3	120	11	15	10	–
A63.70.04.1.K	HSK-A 63	4	120	14	22	20	5
A63.70.05.1.K	HSK-A 63	5	120	16	22	20	5
A63.70.06.1.K	HSK-A 63	6	120	21	27	36	10
A63.70.08.1.K	HSK-A 63	8	120	21	27	36	10
A63.70.10.1.K	HSK-A 63	10	120	24	32	42	10
A63.70.12.1.K	HSK-A 63	12	120	24	32	47	10
A63.70.14.1.K	HSK-A 63	14	120	27	34	47	10
A63.70.16.1.K	HSK-A 63	16	120	27	34	50	10
A63.70.18.1.K	HSK-A 63	18	120	33	42	50	10
A63.70.20.1.K	HSK-A 63	20	120	33	42	52	10
A63.70.25.1.K	HSK-A 63	25	120	44	53	58	10

Für Ø 3, 4 und 5 mm nur Hartmetallschäfte verwenden!

For Ø 3, 4 and 5 mm only solid carbide tool shanks must be used!

Pour Ø 3, 4 et 5 mm il faut seulement utiliser de queues d'outils carbures de type HM!

Hinweis: Aufnahme für Induktiv-, Kontakt- und Heißluftschumpfgeräte geeignet. Schafttoleranz bei Ø 3, 4 und 5 mm = h₄, bei Ø 6–Ø 32 mm = h₆

Note: Toolholders suitable for induction-, contact- and hot air shrink units. Ø 3, 4, 5 with h₄-tolerance and Ø 6–Ø 32 with h₆-tolerance

Observation: Porte-outils convenables pour machines à fretter par induction-, par contact-, ou par air chaud. Ø 3, 4, 5 avec h₄-tolerance et Ø 6–Ø 32 avec h₆-tolerance

l₁ = max. Einstecktiefe

l₁ = max. clamping depth

l₁ = max. profondeur d'insertion

l₂ = max. Verstellweg

l₂ = max. length adjustment range

l₂ = max. course de réglage



Schrumpffutter mit Kühlkanälen zum Spannen von HM und HSS Werkzeugschäften

DIN 69893-1 HSK A

Shrink chucks for mounting of solid carbide and HSS-tool shanks

Mandrins de frettage pour le serrage de queues d'outils carbures de type HM et HSS



Verwendung:

Zur Aufnahme von Werkzeugen mit Zylinderschaft.

Application:

For mounting straight-shank tools.

Application:

Pour le serrage d'outils avec queue cylindrique.

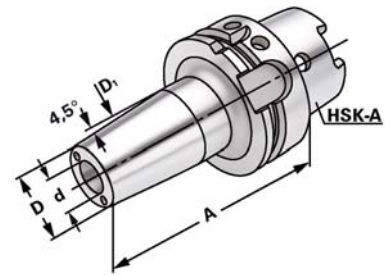

G 6,3 15.000 min⁻¹

≤ 0,003

Bestell-Nr. Order no. Référence	HSK	d	A	D	D ₁	l ₁	l ₂
A63.70.08.2.K	HSK-A 63	8	160	21	27	36	10
A63.70.10.2.K	HSK-A 63	10	160	24	32	42	10
A63.70.12.2.K	HSK-A 63	12	160	24	32	47	10
A63.70.14.2.K	HSK-A 63	14	160	27	34	47	10
A63.70.16.2.K	HSK-A 63	16	160	27	34	50	10
A63.70.18.2.K	HSK-A 63	18	160	33	42	50	10
A63.70.20.2.K	HSK-A 63	20	160	33	42	52	10
A63.70.25.2.K	HSK-A 63	25	160	44	53	58	10
A63.70.32.2.K	HSK-A 63	32	160	44	53	61	10
A100.70.05.K	HSK-A 100	5	80	16	22	20	5
A100.70.06.K	HSK-A 100	6	80	21	27	36	10
A100.70.08.K	HSK-A 100	8	80	21	27	36	10
A100.70.10.K	HSK-A 100	10	85	24	32	42	10
A100.70.12.K	HSK-A 100	12	90	24	32	47	10
A100.70.14.K	HSK-A 100	14	90	27	34	47	10
A100.70.16.K	HSK-A 100	16	95	27	34	50	10
A100.70.18.K	HSK-A 100	18	95	33	42	50	10
A100.70.20.K	HSK-A 100	20	100	33	42	52	10
A100.70.25.K	HSK-A 100	25	115	44	53	58	10
A100.70.32.K	HSK-A 100	32	120	44	53	61	10
A100.70.05.1.K	HSK-A 100	5	120	16	22	20	5
A100.70.06.1.K	HSK-A 100	6	120	21	27	36	10
A100.70.08.1.K	HSK-A 100	8	120	21	27	36	10
A100.70.10.1.K	HSK-A 100	10	120	24	32	42	10
A100.70.12.1.K	HSK-A 100	12	120	24	32	47	10
A100.70.14.1.K	HSK-A 100	14	120	27	34	47	10
A100.70.16.1.K	HSK-A 100	16	120	27	34	50	10
A100.70.18.1.K	HSK-A 100	18	120	33	42	50	10
A100.70.20.1.K	HSK-A 100	20	120	33	42	52	10
A100.70.25.1.K	HSK-A 100	25	120	44	53	58	10
A100.70.32.1.K	HSK-A 100	32	120	44	53	61	10

Hinweis: Aufnahme für Induktiv-, Kontakt- und Heißluftschumpfgeräte geeignet. Schafttoleranz bei Ø 3, 4 und 5 mm = h₄, bei Ø 6–Ø 32 mm = h₆

Note: Toolholders suitable for induction-, contact- and hot air shrink units. Ø 3, 4, 5 with h₄-tolerance and Ø 6–Ø 32 with h₆-tolerance

Observation: Porte-outils convenables pour machines à fretter par induction-, par contact-, ou par air chaud. Ø 3, 4, 5 avec h₄-tolerance et Ø 6–Ø 32 avec h₆-tolerance

l₁ = max. Einstecktiefe

l₁ = max. clamping depth

l₁ = max. profondeur d'insertion

l₂ = max. Verstellweg

l₂ = max. length adjustment range

l₂ = max. course de réglage

Kontrolldorne

Test arbors

Mandrins de contrôle

DIN 69893-1 HSK A



Verwendung:

Zur Abnahme von Werkzeugmaschinen gemäß ISO-Empfehlung R230 oder zur Überprüfung der Werkzeugspindel.

Application:

For the inspection of machine tools according to ISO recommendation R230 or for testing the tool spindle.

Application:

Pour l'inspection de machine-outils suite à la recommandation ISO R230 ou pour la vérification de la broche.

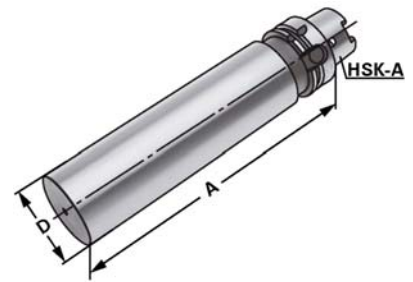

≤ 0,003

Bestell-Nr. Order no. Référence	HSK	D	A	I ₁	I ₂
A32.18.25	HSK-A 32	25	200	180	170
A40.18.25	HSK-A 40	25	200	180	170
A50.18.32	HSK-A 50	32	346	320	300
A63.18.40	HSK-A 63	40	346	320	300
A80.18.50	HSK-A 80	50	346	320	300
A100.18.50	HSK-A 100	50	349	320	300

Holzkasten für Kontrolldorne

Wooden box for test arbors

Coffret en bois pour mandrins de contrôle



Verwendung:

Zur Aufbewahrung von Kontrolldornen.

Application:

For the storage of test arbors.

Application:

Pour la conservation de mandrins de contrôle.



Bestell-Nr. Order no. Référence	Abmessung Size Dimension	für Kegelgrößen for cones pour cônes
701.18	460 × 130 × 115	HSK 32 / 40 / 50 / 63 / 80 / 100



Verwendung:

Zur zentralen Übergabe von Kühlmittel bei HSK-Werkzeugaufnahmen.

Application:

For the coolant supply through the centre of HSK toolholders.

Application:

Pour l'arrosage centrale de porte-outils HSK.

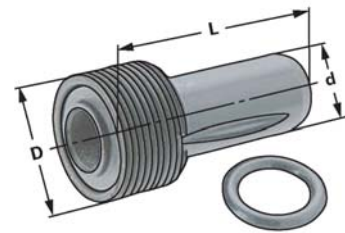

Bestell-Nr. Order no. Référence	HSK	D	d	L
A32.700	HSK 32	M10 × 1	6	26,0
A40.700	HSK 40	M12 × 1	8	29,5
A50.700	HSK 50	M16 × 1	10	33,0
A63.700	HSK 63	M18 × 1	12	34,5
A80.700	HSK 80	M20 × 1,5	14	40,0
A100.700	HSK 100	M24 × 1,5	16	44,0

Hinweis: Axial abgedichtet mit zwei O-Ringen.
Die Kühlmittelübergabeeinheit ist nach dem Einbau, gemäß DIN, minimal beweglich ($\pm 1^\circ$).

Note: Axial sealed with two O-rings.
After mounting, the coolant tube can be moved only to a minimum degree according to DIN ($\pm 1^\circ$).

Observation: Etanche axiale avec deux joints toriques.
Après le montage, la canule de lubrification peut être déplacée légèrement suivant DIN ($\pm 1^\circ$).



Schlüssel für Kühlmittelübergabeeinheiten

Key for coolant tubes

Clés pour canules de lubrification

DIN 69893-1 HSK A



Verwendung:

Zum Montieren der Kühlmittelübergabeeinheiten in HSK-Werkzeugaufnahmen.

Application:

For mounting the coolant tubes in HSK tool-holders.

Application:

Pour le montage de canules de lubrification dans des porte-outils HSK.

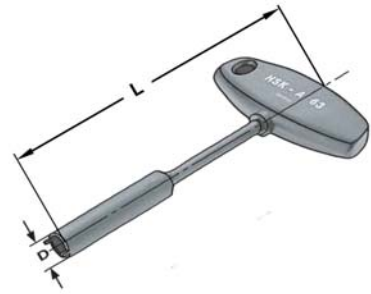

Bestell-Nr. Order no. Référence	HSK	D	L
A32.701	HSK 32	8,5	115
A40.701	HSK 40	10,5	115
A50.701	HSK 50	14,5	115
A63.701	HSK 63	16,5	136
A80.701	HSK 80	18,5	136
A100.701	HSK 100	22,0	136



4.36

Werkzeugaufnahmen DIN 69893-1 (ISO 12164-1) Form C

Toolholders DIN 69893-1 (ISO 12164-1) form C

Porte-outils DIN 69893-1 (ISO 12164-1) forme C

Vorgewuchtet

Pre-balanced
Pré-équilibré

G 6,3 15.000 min⁻¹

G 2,5 Feinwuchten gegen Aufpreis

G 2,5 Fine balancing at extra charge

G 2,5 Equilibrage fin contre un supplément

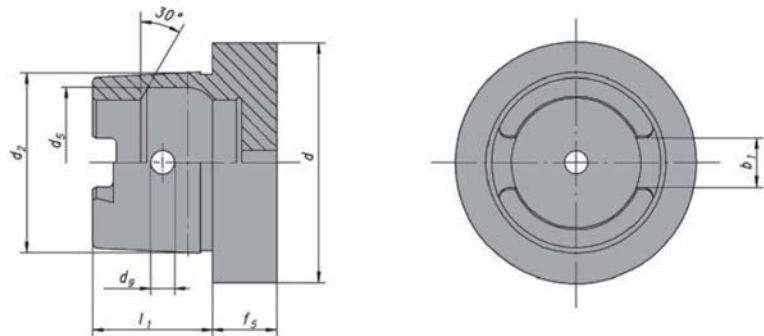

d ₁	l ₁	f ₅	d ₂	d ₅	d ₉	b ₁
32	16	10	24	21	4	7,05
40	20	10	30	25,5	4,6	8,05
50	25	12,5	38	32	6	10,54
63	32	12,5	48	40	7,5	12,54
80	40	16	60	50	8,5	16,04
100	50	16	75	63	12	20,02

Werkstoff: Legierter Einsatzstahl mit einer Zugfestigkeit im Kern von min. 1000 N/mm². Einsatzgehärtet HRC 60 ± 2 (HV 700 ± 50), Härtetiefe 0,8 mm ± 0,2 mm, brüniert und präzisionsgeschliffen.

Genauigkeit: Kegelwinkel – Toleranzqualität < AT 3 nach DIN 7187.

Material: Alloyed case-hardened steel, tensile core strength of min. 1000 N/mm². Case hardened HRC 60 ± 2 (HV 700 ± 50), hardening depth 0.8 mm ± 0.2 mm, black-finished and precisely grinded.

Accuracy: Quality of taper < AT 3 according to DIN 7187.

Matière: Acier de cémentation allié. Résistance à la traction dans le noyau de min 1000 N/mm². Cémentation à HRC 60 ± 2 (HV 700 ± 50), profondeur de cémentation 0,8 mm ± 0,2 mm, bruni et rectifié précisément.

Précision: Qualité du cône < AT 3 suivant DIN 7187.



4.40



4.41



4.45



4.46



4.47



4.48



4.50



4.52

Spannfutter für Spannzangen DIN 6499 (ISO 15488) System ER

DIN 69893-1 HSK C

Collet chucks for collets DIN 6499 (ISO 15488) ER-system

Mandrins à pinces pour pinces DIN 6499 (ISO 15488) système ER



Verwendung:

Zur Aufnahme von Werkzeugen mit Zylinderschaft in Spannzangen.

Application:

For mounting straight-shank tools in collets.

Application:

Pour le serrage d'outils avec queue cylindrique dans des pinces de serrage.

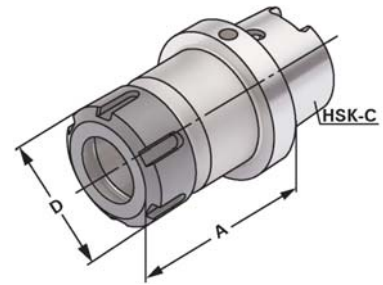

G 6,3 15.000 min⁻¹

≤ 0,003

INFO → 10.03

Bestell-Nr. Order no. Référence	HSK	Spannbereich Capacity Capacité	A	D
C32.02.10	HSK-C 32	1 – 10 (ER 16)	60	28
C40.02.10	HSK-C 40	1 – 10 (ER 16)	60	28
C40.02.16	HSK-C 40	2 – 16 (ER 25)	70	42
C40.02.20	HSK-C 40	2 – 20 (ER 32)	75	50
C40.02.26	HSK-C 40	3 – 26 (ER 40)	85	63
C50.02.10	HSK-C 50	1 – 10 (ER 16)	60	28
C50.02.16	HSK-C 50	2 – 16 (ER 25)	70	42
C50.02.20	HSK-C 50	2 – 20 (ER 32)	80	50
C50.02.26	HSK-C 50	3 – 26 (ER 40)	80	63
C50.02.10.1	HSK-C 50	1 – 10 (ER 16)	100	28
C63.02.10	HSK-C 63	1 – 10 (ER 16)	60	28
C63.02.16	HSK-C 63	1 – 16 (ER 25)	70	42
C63.02.20	HSK-C 63	2 – 20 (ER 32)	75	50
C63.02.26	HSK-C 63	3 – 26 (ER 40)	80	63
C63.02.10.1	HSK-C 63	1 – 10 (ER 16)	100	28
C80.02.10	HSK-C 80	1 – 10 (ER 16)	100	28
C80.02.20	HSK-C 80	2 – 20 (ER 32)	80	50
C80.02.26	HSK-C 80	3 – 26 (ER 40)	85	63
C80.02.10.1	HSK-C 80	1 – 10 (ER 16)	160	28
C100.02.10	HSK-C 100	1 – 10 (ER 16)	100	28
C100.02.20	HSK-C 100	2 – 20 (ER 32)	80	50
C100.02.26	HSK-C 100	3 – 26 (ER 40)	90	63
C100.02.10.1	HSK-C 100	1 – 10 (ER 16)	160	28

Lieferumfang: Mit gewuchteter Spannmutter

Delivery: With balanced clamping nut

Livraison: Avec écrou de serrage équilibré



Fräseraufnahmen DIN 6359 für Zylinderschäfte DIN 1835-B

DIN 69893-1 HSK C

End mill holders DIN 6359 for end mills DIN 1835-B

Porte-fraises DIN 6359 pour queues cylindriques DIN 1835-B



Verwendung:

Zum Spannen von zylindrischen Werkzeugschäften mit seitlicher Spannfläche nach DIN 1835 Form B (Weldon).

Application:

For mounting straight-shank tools with flat according to DIN 1835 form B (Weldon).

Application:

Pour le serrage d'outils avec queue cylindrique et avec méplat suivant DIN 1835 forme B (Weldon).

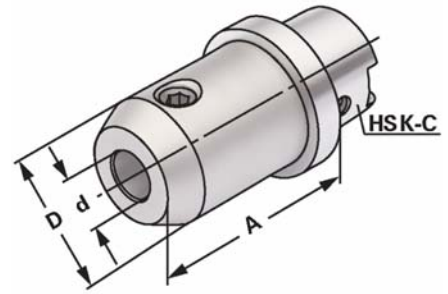

G 6,3 15.000 min⁻¹

≤ 0,003

Bestell-Nr. Order no. Référence	HSK	d ^{H4}	A	D
C40.04.08	HSK-C 40	8	60	28
C40.04.10	HSK-C 40	10	70	35
C40.04.12	HSK-C 40	12	70	42
C40.04.14	HSK-C 40	14	75	44
C40.04.16	HSK-C 40	16	75	48
C40.04.18	HSK-C 40	18	80	50
C40.04.20	HSK-C 40	20	80	52
C50.04.06	HSK-C 50	6	60	25
C50.04.08	HSK-C 50	8	60	28
C50.04.10	HSK-C 50	10	65	35
C50.04.12	HSK-C 50	12	75	42
C50.04.14	HSK-C 50	14	75	44
C50.04.16	HSK-C 50	16	80	48
C50.04.18	HSK-C 50	18	80	50
C50.04.20	HSK-C 50	20	80	52
C63.04.06	HSK-C 63	6	60	25
C63.04.08	HSK-C 63	8	60	28
C63.04.10	HSK-C 63	10	65	35
C63.04.12	HSK-C 63	12	75	42
C63.04.14	HSK-C 63	14	75	44
C63.04.16	HSK-C 63	16	80	48
C63.04.18	HSK-C 63	18	80	50
C63.04.20	HSK-C 63	20	80	52
C63.04.25	HSK-C 63	25	95	65
C63.04.32	HSK-C 63	32	100	72

Hinweis: Ab d = 25 mit zwei Spannschrauben

Note: From d = 25 on two clamping screws

Observation: A partir de d = 25 avec deux vis de serrage

Lieferumfang: Mit Spannschraube

Delivery: With clamping screw

Livraison: Avec vis de serrage



Verwendung:

Zum Spannen von zylindrischen Werkzeugschäften mit seitlicher Spannfläche nach DIN 1835 Form B (Weldon).

Application:

For mounting straight-shank tools with flat according to DIN 1835 form B (Weldon).

Application:

Pour le serrage d'outils avec queue cylindrique et avec méplat suivant DIN 1835 forme B (Weldon).

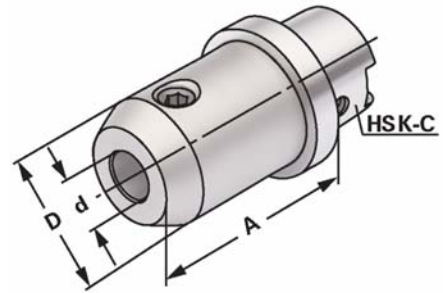

G 6,3 15.000 min⁻¹

≤ 0,003

Bestell-Nr. Order no. Référence	HSK	d ^{H4}	A	D
C100.04.06	HSK-C 100	6	65	25
C100.04.08	HSK-C 100	8	65	28
C100.04.10	HSK-C 100	10	70	35
C100.04.12	HSK-C 100	12	75	42
C100.04.14	HSK-C 100	14	75	44
C100.04.16	HSK-C 100	16	80	48
C100.04.18	HSK-C 100	18	80	50
C100.04.20	HSK-C 100	20	85	52
C100.04.25	HSK-C 100	25	95	65
C100.04.32	HSK-C 100	32	100	72
C100.04.40	HSK-C 100	40	100	80

Hinweis: Ab d = 25 mit zwei Spannschrauben

Note: From d = 25 on two clamping screws

Observation: A partir de d = 25 avec deux vis de serrage

Lieferumfang: Mit Spannschraube

Delivery: With clamping screw

Livraison: Avec vis de serrage

Fräseraufnahmen DIN 6359 für Zylinderschäfte DIN 1835-E DIN 69893-1 HSK C

End mill holders DIN 6359 for end mills DIN 1835-E

Porte-fraises DIN 6359 pour queues cylindriques DIN 1835-E



Verwendung:

Zum Spannen von zylindrischen Werkzeugschäften mit geneigter Spannfläche nach DIN 1835 Form E (Whistle Notch).

Application:

For mounting straight-shank tools and inclined flat according to DIN 1835 form E (Whistle Notch).

Application:

Pour le serrage d'outils avec queue cylindrique et avec méplat incliné suivant DIN 1835 forme E (Whistle Notch).

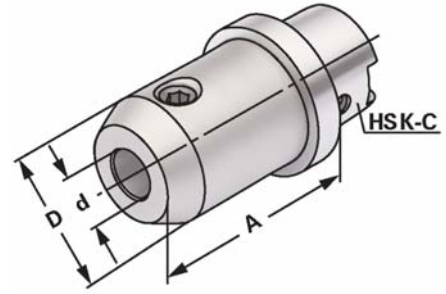

G 6,3 15.000 min⁻¹

≤ 0,003

Bestell-Nr. Order no. Référence	HSK	d ^{H4}	A	D
C32.05.06	HSK-C 32	6	60	25
C32.05.08	HSK-C 32	8	60	28
C32.05.10	HSK-C 32	10	65	35
C32.05.12	HSK-C 32	12	70	42
C32.05.14	HSK-C 32	14	70	44
C40.05.06	HSK-C 40	6	60	25
C40.05.08	HSK-C 40	8	60	28
C40.05.10	HSK-C 40	10	65	35
C40.05.12	HSK-C 40	12	70	42
C40.05.14	HSK-C 40	14	70	44
C40.05.16	HSK-C 40	16	75	48
C40.05.18	HSK-C 40	18	75	50
C40.05.20	HSK-C 40	20	80	57
C50.05.06	HSK-C 50	6	60	25
C50.05.08	HSK-C 50	8	60	28
C50.05.10	HSK-C 50	10	65	35
C50.05.12	HSK-C 50	12	75	42
C50.05.14	HSK-C 50	14	75	44
C50.05.16	HSK-C 50	16	80	48
C50.05.18	HSK-C 50	18	80	50
C50.05.20	HSK-C 50	20	80	52
C50.05.25	HSK-C 50	25	85	65

Hinweis: Ab d = 25 mit zwei Spannschrauben
Note: From d = 25 on two clamping screws
Observation: A partir de d = 25 avec deux vis de serrage

Lieferumfang: Mit Spannschraube und axialer Verstellechraube
Delivery: With clamping screw and axial adjustment bolt
Livraison: Avec vis de serrage et vis de butée axiale

Verwendung:

Zum Spannen von zylindrischen Werkzeugschäften mit geneigter Spannfläche nach DIN 1835 Form E (Whistle Notch).

Application:

For mounting straight-shank tools and inclined flat according to DIN 1835 form E (Whistle Notch).

Application:

Pour le serrage d'outils avec queue cylindrique et avec méplat incliné suivant DIN 1835 forme E (Whistle Notch).

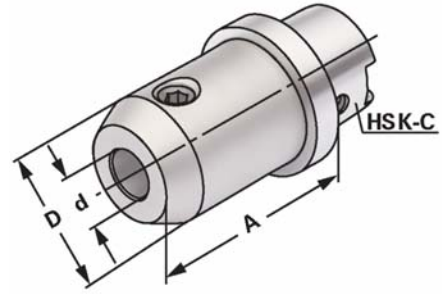
G 6,3 15.000 min⁻¹
↗ ≤ 0,003

Bestell-Nr. Order no. Référence	HSK	d ^{H4}	A	D
C63.05.06	HSK-C 63	6	60	25
C63.05.08	HSK-C 63	8	60	28
C63.05.10	HSK-C 63	10	65	35
C63.05.12	HSK-C 63	12	75	42
C63.05.14	HSK-C 63	14	75	44
C63.05.16	HSK-C 63	16	80	48
C63.05.18	HSK-C 63	18	80	50
C63.05.20	HSK-C 63	20	80	52
C63.05.25	HSK-C 63	25	95	65
C63.05.32	HSK-C 63	32	100	72
C80.05.06	HSK-C 80	6	65	25
C80.05.08	HSK-C 80	8	65	28
C80.05.10	HSK-C 80	10	70	35
C80.05.12	HSK-C 80	12	75	42
C80.05.14	HSK-C 80	14	75	44
C80.05.16	HSK-C 80	16	80	48
C80.05.18	HSK-C 80	18	80	50
C80.05.20	HSK-C 80	20	85	52
C80.05.25	HSK-C 80	25	95	65
C80.05.32	HSK-C 80	32	100	72
C100.05.06	HSK-C 100	6	65	25
C100.05.08	HSK-C 100	8	65	28
C100.05.10	HSK-C 100	10	70	35
C100.05.12	HSK-C 100	12	75	42
C100.05.14	HSK-C 100	14	75	44
C100.05.16	HSK-C 100	16	80	48
C100.05.18	HSK-C 100	18	80	50
C100.05.20	HSK-C 100	20	85	52
C100.05.25	HSK-C 100	25	95	65
C100.05.32	HSK-C 100	32	100	72

Hinweis: Ab d = 25 mit zwei Spannschrauben

Note: From d = 25 on two clamping screws

Observation: A partir de d = 25 avec deux vis de serrage

Lieferumfang: Mit Spannschraube und axialer Verstellechraube

Delivery: With clamping screw and axial adjustment bolt

Livraison: Avec vis de serrage et vis de butée axiale

Quernut-Aufsteckfräserdorne DIN 6357 mit vergrößerter Anlagefläche

DIN 69893-1 HSK C



Shell mill holders DIN 6357 with enlarged contact face

Porte-fraises à trou lisse DIN 6357 avec face de contact élargie



Verwendung:

Zur Aufnahme von Messerköpfen und Fräsern mit Quernut.

Application:

For mounting milling cutters with transversal groove.

Application:

Pour le serrage de fraises à rainure transversale.

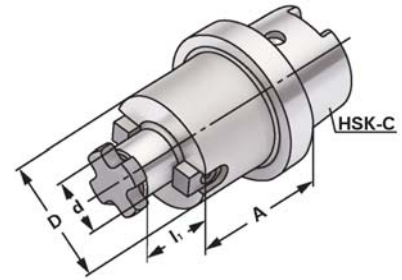

G 6,3 15.000 min⁻¹

≤ 0,005

Bestell-Nr. Order no. Référence	HSK	d _{h6}	A	D	I
C40.11.16	HSK-C 40	16	50	40	17
C40.11.22	HSK-C 40	22	60	40	19
C50.11.16	HSK-C 50	16	60	40	17
C50.11.22	HSK-C 50	22	60	50	19
C50.11.27	HSK-C 50	27	60	50	21
C63.11.22	HSK-C 63	22	50	48	19
C63.11.27	HSK-C 63	27	60	60	21
C63.11.32	HSK-C 63	32	60	78	24
C63.11.40	HSK-C 63	40	60	89	27
C80.11.32	HSK-C 80	32	48	78	24
C80.11.40	HSK-C 80	40	60	89	27
C80.11.32.1	HSK-C 80	32	60	78	24
C100.11.22	HSK-C 100	22	50	48	19
C100.11.27	HSK-C 100	27	50	60	21
C100.11.32	HSK-C 100	32	50	78	24
C100.11.40	HSK-C 100	40	60	89	27
C100.11.50	HSK-C 100	50	70	120	30

d = 40/d = 50: Für große Planfräser mit vier zusätzlichen Gewindebohrungen nach DIN 2079.

For large diameter face mill cutters with four additional threaded holes according to DIN 2079.

Pour fraises à surfacer à grands diamètres avec quatre trous taraudés additionnels suivant DIN 2079.

Lieferumfang: Mit Mitnehmersteinen und Kreuzschraube.

Delivery: With drivers and cross head retaining screw.

Livraison: Avec tenons et une vis cruciforme.



CNC-Bohrfutter für Rechts- und Linkslauf

CNC-Drill chucks for clockwise and counter clockwise rotation

Mandrins de perçage CNC pour rotation gauche-droite

DIN 69893-1 HSK C



Verwendung:

Zur Aufnahme von Werkzeugen mit Zylinderschaft.

Application:

For mounting tools with straight shanks.

Application:

Pour le serrage d'outils avec queue cylindrique.

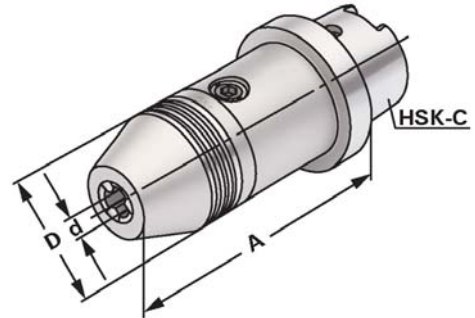

G 6,3 15.000 min⁻¹

≤ 0,03

INFO → 10.03

Bestell-Nr. Order no. Référence	HSK	Spannbereich Capacity Capacité d	A	D
C50.15.13	HSK-C 50	1,0 – 13	110	50
C50.15.16	HSK-C 50	2,5 – 16	115,5	50
C63.15.13	HSK-C 63	1,0 – 13	110	50
C63.15.16	HSK-C 63	2,5 – 16	115,5	50
C100.15.13	HSK-C 100	1,0 – 13	112,5	50
C100.15.16	HSK-C 100	2,5 – 16	118	50

Hinweis: Hohe Präzision und Rundlaufgenauigkeit von ≤ 0,03 mm. Sichere Spannung des Werkzeuges durch mechanische Spannkraftverstärkung. Kein selbständiges Lösen der Spannung während der Bearbeitung bei Links- oder Rechtslauf, sowie bei Spindelstop. Spannen und Lösen mit Sechskantschlüssel.

Note: High precision and accurate concentricity of ≤ 0.03 mm. Secure gripping of the tool through mechanical amplification of the clamping force. No automatic slackening of the clamping force while machining with either clockwise or counter clockwise rotation or on spindle stop. Clamping and releasing effected by means of an Allen wrench.

Observation: Précision élevée et exactitude de circularité de ≤ 0,03 mm. Serrage sûr de l'outil grâce à l'amplification de la force de serrage. Pas de desserrage intempestif en cours d'usinage lors de la rotation la gauche ou la droite, de même qu'en cas d'arrêt de la broche. Serrage et desserrage en utilisant un clé sur à fourche.

Lieferumfang: Mit Spannschlüssel

Delivery: With wrench

Livraison: Avec clé de serrage

Bohrstangenrohlinge

Boring bar blanks
Barres d'alésage

DIN 69893-1 HSK C



Verwendung:
Zur Herstellung von Sonderwerkzeugen.
Application:
For the manufacturing of special tools.
Application:
Pour la fabrication d'outils spéciaux.

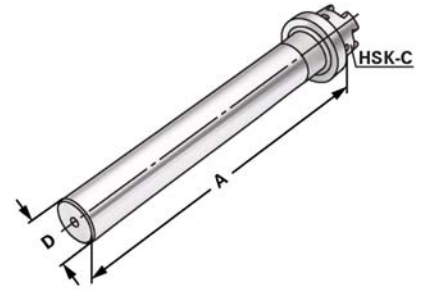

Bestell-Nr. Order no. Référence	HSK	A	D
C32.17.32	HSK-C 32	160	32,5
C40.17.40	HSK-C 40	160	40,5
C50.17.50	HSK-C 50	200	50,5
C63.17.63	HSK-C 63	250	63,5
C80.17.80	HSK-C 80	250	80,5
C100.17.93	HSK-C 100	250	93,5

Ausführung: Steilkegel und Bund gehärtet und geschliffen. Schaft weich zur weiteren Bearbeitung.

Version: Cone and flange hardened and grinded. Soft body for later processing.

Version: Cône et collerette durcis et rectifiés. Corps doux pour un usinage ultérieur.

Kontrolldorne

Test arbors

Mandrins de contrôle

DIN 69893-1 HSK C



Verwendung:

Zur Abnahme von Werkzeugmaschinen gemäß ISO-Empfehlung R230 oder zur Überprüfung der Werkzeugspindel.

Application:

For the inspection of machine tools according to ISO recommendation R230 or for testing the tool spindle.

Application:

Pour l'inspection de machine-outils suite à la recommandation ISO R230 ou pour la vérification de la broche.

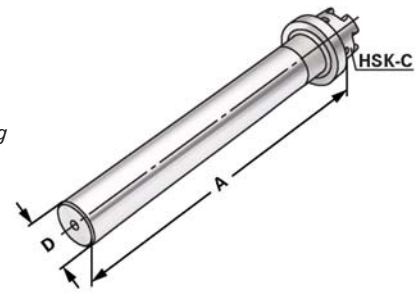

≤ 0,003

Bestell-Nr. Order no. Référence	HSK	D	A	l ₁	l ₂
C32.18.25	HSK-C 32	25	160	150	140
C40.18.25	HSK-C 40	25	160	150	140
C50.18.32	HSK-C 50	32	300	287,5	275
C63.18.40	HSK-C 63	40	300	287,5	275
C80.18.40	HSK-C 80	40	300	284	275
C100.18.50	HSK-C 100	50	300	284	275

Holzkasten für Kontrolldorne

Wooden box for test arbors

Coffret en bois pour mandrins de contrôle



Verwendung:

Zur Aufbewahrung von Kontrolldornen.

Application:

For the storage of test arbors.

Application:

Pour la conservation de mandrins de contrôle.



Bestell-Nr. Order no. Référence	Abmessung Size Dimension	für Kegelgrößen for cones pour cônes
701.18	460 × 130 × 115	HSK 32 / 40 / 50 / 63 / 80 / 100

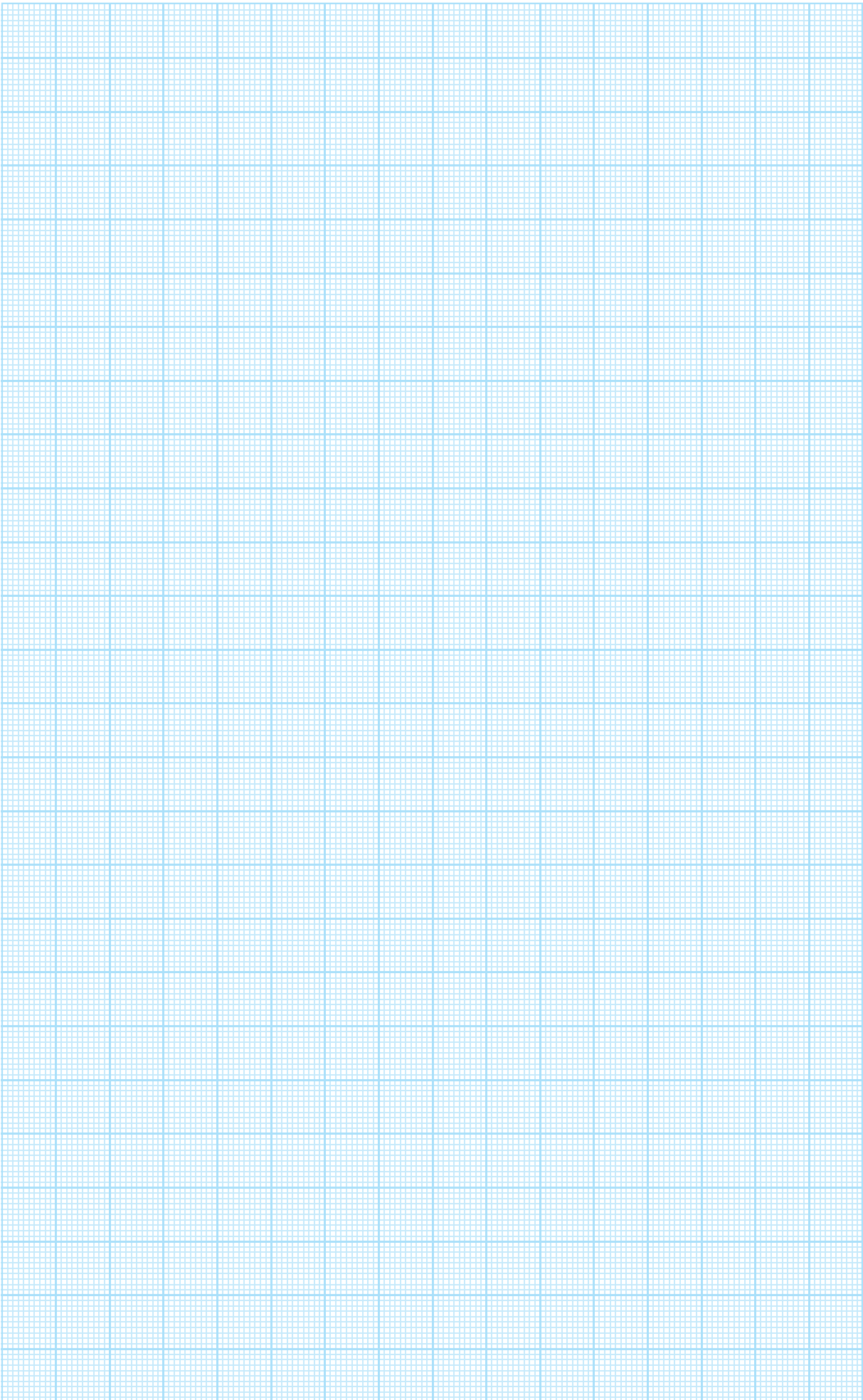



Verwendung:

Zur Aufnahme von Werkzeugen mit Zylinderschaft nach DIN 1835 Form A+B+E und DIN 6535 Form HA+HB+HE (größer Ø 20 mm nur mit Reduzierung).

Application:

For mounting straight-shank tools acc. DIN 1835 form A+B+E and DIN 6535 form HA+HB+HE (larger than dia. 20 mm only with reduction sleeve).

Application:

Pour le serrage d'outils avec queue cylindrique suivant DIN 1835 forme A+B+E et DIN 6535 forme HA+HB+HE (à partir de dia. 20 mm seulement avec réduction).

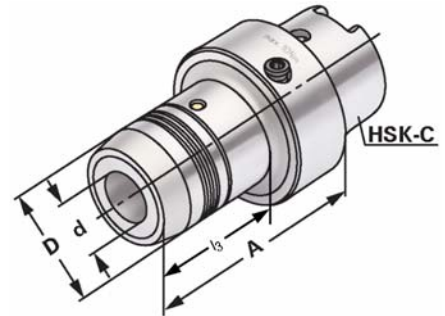

G 6,3 15.000 min⁻¹

≤ 0,003

INFO → 10.03

Bestell-Nr. Order no. Référence	HSK	d	A	D	l ₁	l ₂	l ₃
C25.H06	HSK-C 25	6	60	26	37	10	38
C25.H08	HSK-C 25	8	60	28	37	10	38
C25.H10	HSK-C 25	10	65	30	42	10	38
C32.H06	HSK-C 32	6	60	26	37	10	35
C32.H08	HSK-C 32	8	60	28	37	10	36
C32.H10	HSK-C 32	10	65	30	42	10	52
C32.H12	HSK-C 32	12	70	32	47	10	-
C32.H14	HSK-C 32	14	75	34	47	10	65
C32.H06.1	HSK-C 32	6	67	26	37	10	42
C32.H10.1	HSK-C 32	10	72,5	30	42	10	48,5
C32.H12.1	HSK-C 32	12	76	32	47	10	-
C40.H06	HSK-C 40	6	60	26	37	10	35
C40.H08	HSK-C 40	8	60	28	37	10	36
C40.H10	HSK-C 40	10	65	30	42	10	38
C40.H12	HSK-C 40	12	70	32	47	10	47
C40.H14	HSK-C 40	14	80	34	47	10	49
C40.H16	HSK-C 40	16	80	38	52	10	49
C40.H18	HSK-C 40	18	80	40	52	10	49
C40.H20	HSK-C 40	20	80	42	52	10	49
C50.H06	HSK-C 50	6	60	26	37	10	33
C50.H08	HSK-C 50	8	60	28	37	10	33
C50.H10	HSK-C 50	10	65	30	42	10	39
C50.H12	HSK-C 50	12	75	32	47	10	44
C50.H14	HSK-C 50	14	75	34	47	10	46
C50.H16	HSK-C 50	16	80	38	52	10	51
C50.H18	HSK-C 50	18	80	40	52	10	52
C50.H20	HSK-C 50	20	80	42	52	10	58

Lieferumfang: Mit Spannschlüssel

Delivery: With wrench

Livraison: Avec clé de serrage

l₁ = max. Einstecktiefe

l₁ = max. clamping depth

l₁ = max. profondeur d'insertion

l₂ = max. Verstellweg

l₂ = max. length adjustment range

l₂ = max. course de réglage



Hydro-Dehnspannfutter

Hydraulic expansion chucks

Mandrins expansibles hydrauliques

DIN 69893-1 HSK C



G 6,3 15.000 min⁻¹

≤ 0,003

Verwendung:

Zur Aufnahme von Werkzeugen mit Zylinderschaft nach DIN 1835 Form A+B+E und DIN 6535 Form HA+HB+HE (größer Ø 20 mm nur mit Reduzierung).

Application:

For mounting straight-shank tools acc. DIN 1835 form A+B+E and DIN 6535 form HA+HB+HE (larger than dia. 20 mm only with reduction sleeve).

Application:

Pour le serrage d'outils avec queue cylindrique suivant DIN 1835 forme A+B+E et DIN 6535 forme HA+HB+HE (à partir de dia. 20 mm seulement avec réduction).

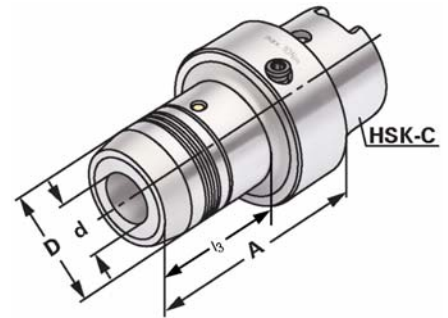

INFO ➔ 10.03

Bestell-Nr. Order no. Référence	HSK	d	A	D	l ₁	l ₂	l ₃
C63.H06	HSK-C 63	6	60	26	37	10	29
C63.H08	HSK-C 63	8	60	28	37	10	29
C63.H10	HSK-C 63	10	65	30	42	10	35
C63.H12	HSK-C 63	12	75	32	47	10	40
C63.H14	HSK-C 63	14	75	34	47	10	42
C63.H16	HSK-C 63	16	80	38	52	10	47
C63.H18	HSK-C 63	18	80	40	52	10	48
C63.H20	HSK-C 63	20	80	42	52	10	54
C63.H25	HSK-C 63	25	95	50	58	10	51
C63.H32	HSK-C 63	32	100	60	62	10	59

Lieferumfang: Mit Spannschlüssel

Delivery: With wrench

Livraison: Avec clé de serrage

l₁ = max. Einstecktiefe

l₁ = max. clamping depth

l₁ = max. profondeur d'insertion

l₂ = max. Verstellweg

l₂ = max. length adjustment range

l₂ = max. course de réglage



7.66-7.67

Schrumpffutter zum Spannen von HM und HSS Werkzeugschäften

DIN 69893-1 HSK C

Shrink chucks for mounting of solid carbide and HSS-tool shanks

Mandrins de frettage pour le serrage de queues d'outils carbures de type HM et HSS



Verwendung:

Zur Aufnahme von Werkzeugen mit Zylinderschaft.

Application:

For mounting straight-shank tools.

Application:

Pour le serrage d'outils avec queue cylindrique.

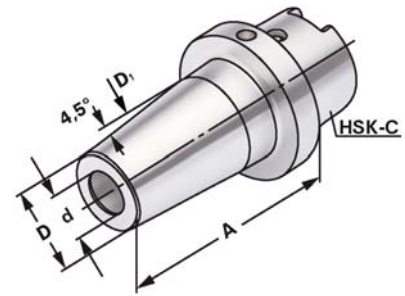

G 6,3 15.000 min⁻¹

≤ 0,003

Bestell-Nr. Order no. Référence	HSK	d	A	D	D ₁	l ₁	l ₂
C32.70.06	HSK-C 32	6	65	21	27	36	10
C32.70.08	HSK-C 32	8	65	21	27	36	10
C32.70.10	HSK-C 32	10	65	24	32	42	10
C32.70.12	HSK-C 32	12	75	24	32	47	10
C32.70.14	HSK-C 32	14	80	27	34	47	10
C32.70.16	HSK-C 32	16	80	27	34	50	10
C32.70.06.1	HSK-C 32	6	75	21	27	36	10
C32.70.08.1	HSK-C 32	8	75	21	27	36	10
C32.70.10.1	HSK-C 32	10	80	24	32	42	10
C40.70.03	HSK-C 40	3	70	11	15	10	–
C40.70.04	HSK-C 40	4	70	14	22	20	5
C40.70.05	HSK-C 40	5	70	16	22	20	5
C40.70.06	HSK-C 40	6	70	21	27	36	10
C40.70.08	HSK-C 40	8	70	21	27	36	10
C40.70.10	HSK-C 40	10	70	24	32	42	10
C40.70.12	HSK-C 40	12	80	24	32	47	10
C40.70.14	HSK-C 40	14	80	27	34	47	10
C40.70.16	HSK-C 40	16	80	27	34	50	10
C40.70.18	HSK-C 40	18	80	33	42	50	10
C40.70.20	HSK-C 40	20	80	33	42	52	10
C50.70.06	HSK-C 50	6	70	21	27	36	10
C50.70.08	HSK-C 50	8	70	21	27	36	10
C50.70.10	HSK-C 50	10	75	24	32	42	10
C50.70.12	HSK-C 50	12	75	24	32	47	10
C50.70.14	HSK-C 50	14	80	27	34	47	10
C50.70.16	HSK-C 50	16	85	27	34	50	10
C50.70.18	HSK-C 50	18	85	33	42	50	10
C50.70.20	HSK-C 50	20	90	33	42	52	10

Hinweis: Aufnahme für Induktiv-, Kontakt- und Heißluftschumpfgeräte geeignet. Schafttoleranz bei Ø 3, 4 und 5 mm = h₄, bei Ø 6–Ø 32 mm = h₆

Note: Toolholders suitable for induction-, contact- and hot air shrink units. Ø 3, 4, 5 with h₄-tolerance and Ø 6–Ø 32 with h₆-tolerance

Observation: Porte-outils convenables pour machines à frotter par induction-, par contact-, ou par air chaud. Ø 3, 4, 5 avec h₄-tolerance et Ø 6–Ø 32 avec h₆-tolerance

l₁ = max. Einstecktiefe

l₁ = max. clamping depth

l₁ = max. profondeur d'insertion

l₂ = max. Verstellweg

l₂ = max. length adjustment range

l₂ = max. course de réglage

Schrumpffutter zum Spannen von HM und HSS Werkzeugschäften

DIN 69893-1 HSK C



Shrink chucks for mounting of solid carbide and HSS-tool shanks

Mandrins de frettage pour le serrage de queues d'outils carbures de type HM et HSS



Verwendung:

Zur Aufnahme von Werkzeugen mit Zylinderschaft.

Application:

For mounting straight-shank tools.

Application:

Pour le serrage d'outils avec queue cylindrique.

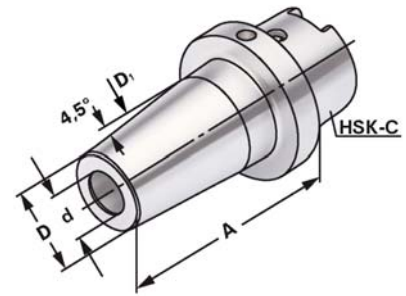

G 6,3 15.000 min⁻¹

≤ 0,003

Bestell-Nr. Order no. Référence	HSK	d	A	D	D ₁	l ₁	l ₂
C63.70.06	HSK-C 63	6	70	21	27	36	10
C63.70.08	HSK-C 63	8	70	21	27	36	10
C63.70.10	HSK-C 63	10	75	24	32	42	10
C63.70.12	HSK-C 63	12	80	24	32	47	10
C63.70.14	HSK-C 63	14	80	27	34	47	10
C63.70.16	HSK-C 63	16	85	27	34	50	10
C63.70.18	HSK-C 63	18	85	33	42	50	10
C63.70.20	HSK-C 63	20	90	33	42	52	10
C63.70.25	HSK-C 63	25	100	44	53	58	10
C63.70.32	HSK-C 63	32	110	44	53	61	10

Hinweis: Aufnahme für Induktiv-, Kontakt- und Heißluftschumpfgeräte geeignet.
Schafttoleranz bei Ø 6–Ø 32 mm = h₆

Note: Toolholders suitable for induction-, contact- and hot air shrink units.
Ø 6–Ø 32 with h₆-tolerance

Observation: Porte-outils convenables pour machines à fretter par induction-,
par contact-, ou par air chaud.
Ø 6–Ø 32 avec h₆-tolerance

l₁ = max. Einstecktiefe

l₁ = max. clamping depth

l₁ = max. profondeur d'insertion

l₂ = max. Verstellweg

l₂ = max. length adjustment range

l₂ = max. course de réglage



7.65

Werkzeugaufnahmen DIN 69893-5 Form E

Toolholders DIN 69893-5 form E

Porte-outils DIN 69893-5 forme E

Vorgewuchtet

Pre-balanced
Pré-équilibré

G 6,3 15.000 min⁻¹

G 2,5 Feinwuchten gegen Aufpreis

G 2.5 Fine balancing at extra charge

G 2,5 Equilibrage fin contre un supplément

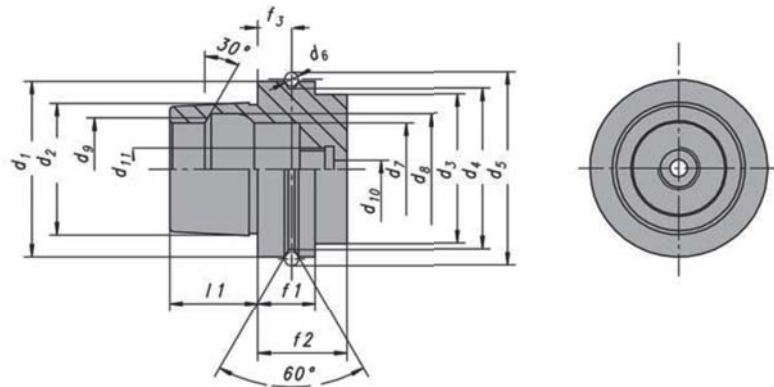

d ₁	d ₂	d ₃	d ₄	d ₅ -0,1	d ₆ -0,1	d ₈ ^{H10}	d ₉ ^{H11}	d ₁₀	f ₁ -0,1	f ₂ min.	f ₃ ±0,1	l ₁ -0,2	l ₂ js10	l ₃
25	19 ^{+0,006} / _{+0,004}	18,15	20	22	28,5	14	16,4	15	10	20	4,5	13	7,21	8,5
32	24 ^{+0,007} / _{+0,005}	23,27	26	26,5	37	17	21	19	20	35	16	16	8,92	7,3
40	30 ^{+0,007} / _{+0,005}	29,05	34	34,8	45	21	25,5	23	20	35	16	20	11,42	9,5
50	38 ^{+0,009} / _{+0,006}	36,90	42	43	59,3	26	32	29	26	42	18	25	14,13	11,0
63	48 ^{+0,011} / _{+0,007}	46,53	53	55	72,3	34	40	37	26	42	18	32	18,13	14,7

Werkstoff: Legierter Einsatzstahl mit einer Zugfestigkeit im Kern von min. 1000 N/mm². Einsatzgehärtet HRC 60 ± 2 (HV 700 ± 50), Härtetiefe 0,8 mm ± 0,2 mm, brüniert und präzisionsgeschliffen.

Genauigkeit: Kegelwinkel – Toleranzqualität < AT 3 nach DIN 7187.

Material: Alloyed case-hardened steel, tensile core strength of min. 1000 N/mm². Case hardened HRC 60 ± 2 (HV 700 ± 50), hardening depth 0.8 mm ± 0.2 mm, black-finished and precisely grinded.

Accuracy: Quality of taper < AT 3 according to DIN 7187.

Matière: Acier de cémentation allié. Résistance à la traction dans le noyau de min 1000 N/mm². Cémentation à HRC 60 ± 2 (HV 700 ± 50), profondeur de cémentation 0,8 mm ± 0,2 mm, bruni et rectifié précisément.

Précision: Qualité du cône < AT 3 suivant DIN 7187.



4.56



4.57



4.59



4.60



4.61



4.62



4.64

Spannfutter für Spannzangen DIN 6499 (ISO 15488) System ER

DIN 69893-5 HSK E

Collet chucks for collets DIN 6499 (ISO 15488) ER-system

Mandrins à pinces pour pinces DIN 6499 (ISO 15488) système ER



Verwendung:

Zur Aufnahme von Werkzeugen mit Zylinderschaft in Spannzangen.

Application:

For mounting straight-shank tools in collets.

Application:

Pour le serrage d'outils avec queue cylindrique dans des pinces de serrage.

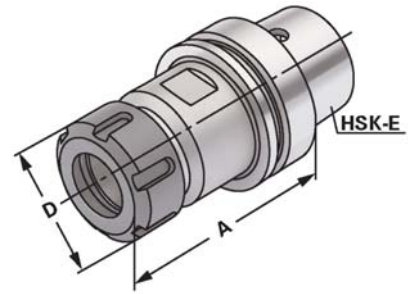

G 6,3 15.000 min⁻¹

≤ 0,003

INFO → 10.03

Bestell-Nr. Order no. Référence	HSK	Spannbereich Capacity Capacité	A	D
E25.02.10	HSK-E 25	1 – 10 (ER 16)	65	28
E25.02.16	HSK-E 25	1 – 16 (ER 25)	70	42
E32.02.16	HSK-E 32	1 – 16 (ER 25)	75	35
E32.02.20	HSK-E 32	2 – 20 (ER 32)	85	50
E40.02.10	HSK-E 40	1 – 10 (ER 16)	65	28
E40.02.16	HSK-E 40	1 – 16 (ER 25)	75	42
E40.02.20	HSK-E 40	2 – 20 (ER 32)	75	50
E50.02.10	HSK-E 50	1 – 10 (ER 16)	60	28
E50.02.16	HSK-E 50	1 – 16 (ER 25)	80	42
E50.02.20	HSK-E 50	2 – 20 (ER 32)	80	50
E50.02.26	HSK-E 50	3 – 26 (ER 40)	85	63
E63.02.16	HSK-E 63	1 – 16 (ER 25)	75	42
E63.02.20	HSK-E 63	2 – 20 (ER 32)	80	50
E63.02.26	HSK-E 63	3 – 26 (ER 40)	90	63
E63.02.16.1	HSK-E 63	1 – 10 (ER 16)	120	28

Lieferumfang: Mit gewuchteter Spannmutter

Delivery: With balanced clamping nut

Livraison: Avec écrou de serrage équilibré



Fräseraufnahmen DIN 6359 für Zylinderschäfte DIN 1835-B

DIN 69893-5 HSK E

End mill holders DIN 6359 for end mills DIN 1835-B

Porte-fraises DIN 6359 pour queues cylindriques DIN 1835-B



Verwendung:

Zum Spannen von zylindrischen Werkzeugschäften mit seitlicher Spannfläche nach DIN 1835 Form B (Weldon).

Application:

For mounting straight-shank tools with flat according to DIN 1835 form B (Weldon).

Application:

Pour le serrage d'outils avec queue cylindrique et avec méplat suivant DIN 1835 forme B (Weldon).

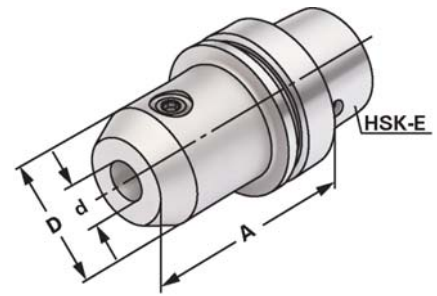

G 6,3 15.000 min⁻¹

≤ 0,003

Bestell-Nr. Order no. Référence	HSK	d ^{H4}	A	D
E32.04.06	HSK-E 32	6	60	25
E32.04.08	HSK-E 32	8	60	28
E32.04.10	HSK-E 32	10	65	35
E40.04.06	HSK-E 40	6	60	25
E40.04.08	HSK-E 40	8	60	28
E40.04.10	HSK-E 40	10	60	35
E40.04.12	HSK-E 40	12	70	42
E40.04.14	HSK-E 40	14	75	44
E40.04.16	HSK-E 40	16	75	48
E50.04.06	HSK-E 50	6	65	25
E50.04.08	HSK-E 50	8	65	28
E50.04.10	HSK-E 50	10	65	35
E50.04.12	HSK-E 50	12	80	42
E50.04.14	HSK-E 50	14	80	44
E50.04.16	HSK-E 50	16	80	48
E50.04.18	HSK-E 50	18	80	50
E50.04.20	HSK-E 50	20	80	52
E50.04.25	HSK-E 50	25	102	65
E63.04.06	HSK-E 63	6	65	15
E63.04.08	HSK-E 63	8	65	20
E63.04.10	HSK-E 63	10	65	25
E63.04.12	HSK-E 63	12	80	30
E63.04.14	HSK-E 63	14	80	32
E63.04.16	HSK-E 63	16	80	36
E63.04.18	HSK-E 63	18	80	38
E63.04.20	HSK-E 63	20	80	40
E63.04.25	HSK-E 63	25	110	46
E63.04.32	HSK-E 63	32	110	64

Hinweis: Ab d = 25 mit zwei Spanschrauben

Note: From d = 25 on two clamping screws

Observation: A partir de d = 25 avec deux vis de serrage

Lieferumfang: Mit Spanschraube

Delivery: With clamping screw

Livraison: Avec vis de serrage

Verwendung:

Zum Spannen von zylindrischen Werkzeugschäften mit geneigter Spannfläche nach DIN 1835 Form E (Whistle Notch).

Application:

For mounting straight-shank tools and inclined flat according to DIN 1835 form E (Whistle Notch).

Application:

Pour le serrage d'outils avec queue cylindrique et avec méplat incliné suivant DIN 1835 forme E (Whistle Notch).

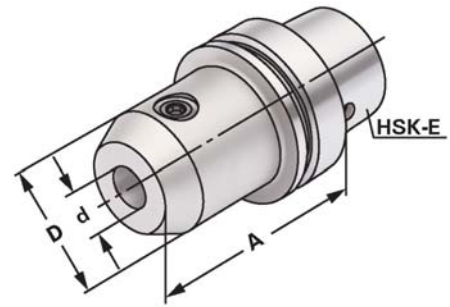
G 6,3 15.000 min⁻¹
↗ ≤ 0,003

Bestell-Nr. Order no. Référence	HSK	d ^{H4}	A	D
E32.05.06	HSK-E 32	6	60	25
E32.05.08	HSK-E 32	8	80	28
E32.05.10	HSK-E 32	10	80	35
E40.05.06	HSK-E 40	6	60	25
E40.05.08	HSK-E 40	8	80	28
E40.05.10	HSK-E 40	10	80	35
E40.05.12	HSK-E 40	12	90	42
E40.05.14	HSK-E 40	14	90	44
E40.05.16	HSK-E 40	16	90	48
E50.05.06	HSK-E 50	6	80	25
E50.05.08	HSK-E 50	8	80	28
E50.05.10	HSK-E 50	10	80	35
E50.05.12	HSK-E 50	12	90	42
E50.05.14	HSK-E 50	14	90	44
E50.05.16	HSK-E 50	16	90	48
E50.05.18	HSK-E 50	18	90	50
E50.05.20	HSK-E 50	20	100	52
E63.05.06	HSK-E 63	6	80	25
E63.05.08	HSK-E 63	8	80	28
E63.05.10	HSK-E 63	10	80	35
E63.05.12	HSK-E 63	12	90	42
E63.05.14	HSK-E 63	14	90	44
E63.05.16	HSK-E 63	16	100	48
E63.05.18	HSK-E 63	18	100	50
E63.05.20	HSK-E 63	20	100	52
E63.05.25	HSK-E 63	25	110	65
E63.05.32	HSK-E 63	32	110	72

Hinweis: Ab d = 25 mit zwei Spanschrauben

Note: From d = 25 on two clamping screws

Observation: A partir de d = 25 avec deux vis de serrage

Lieferumfang: Mit Spanschraube und axialer Verstellechraube

Delivery: With clamping screw and axial adjustment bolt

Livraison: Avec vis de serrage et vis de butée axiale

Quernut-Aufsteckfräserdorne DIN 6357 mit vergrößerter Anlagefläche

DIN 69893-5 HSK E



Shell mill holders DIN 6357 with enlarged contact face

Porte-fraises à trou lisse DIN 6357 avec face de contact élargie



Verwendung:

Zur Aufnahme von Messerköpfen und Fräsern mit Quernut.

Application:

For mounting milling cutters with transversal groove.

Application:

Pour le serrage de fraises à rainure transversale.

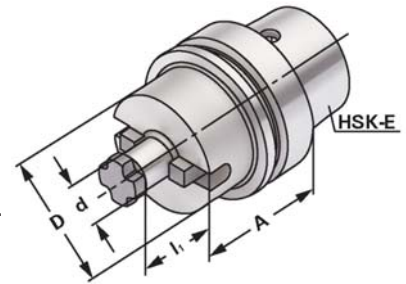

G 6,3 15.000 min⁻¹

≤ 0,005

Bestell-Nr. Order no. Référence	HSK	d _{h6}	A	l	D
E32.11.16	HSK-E 32	16	50	17	34
E40.11.16	HSK-E 40	16	50	17	34
E40.11.22	HSK-E 40	22	50	19	48
E40.11.27	HSK-E 40	27	55	21	60
E50.11.16	HSK-E 50	16	50	17	38
E50.11.22	HSK-E 50	22	60	19	48
E50.11.27	HSK-E 50	27	60	21	58
E63.11.16	HSK-E 63	16	50	17	38
E63.11.22	HSK-E 63	22	60	19	48
E63.11.27	HSK-E 63	27	60	21	58
E63.11.32	HSK-E 63	32	60	24	65

Lieferumfang: Mit Mitnehmersteinen und Kreuzschraube.

Delivery: With drivers and cross head retaining screw.

Livraison: Avec tenons and une vis cruciforme.



CNC-Bohrfutter für Rechts- und Linkslauf

CNC-Drill chucks for clockwise and counter clockwise rotation

Mandrins de perçage CNC pour rotation gauche-droite

DIN 69893-5 HSK E



Verwendung:

Zur Aufnahme von Werkzeugen mit Zylinderschaft.

Application:

For mounting tools with straight shanks.

Application:

Pour le serrage d'outils avec queue cylindrique.

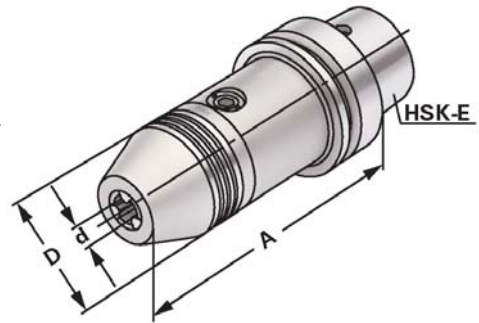

G 6,3 15.000 min⁻¹

≤ 0,03

INFO → 10.03

Bestell-Nr. Order no. Référence	HSK	Spannbereich Capacity Capacité d	A	D
E25.15.08	HSK-E 25	0 – 8	70,0	36
E32.15.08	HSK-E 32	0 – 8	75,0	36
E40.15.08	HSK-E 40	0 – 8	80,0	36
E40.15.13	HSK-E 40	1,0 – 13	119,0	50
E40.15.16	HSK-E 40	2,5 – 16	124,5	50
E50.15.13	HSK-E 50	1,0 – 13	121,0	50
E50.15.16	HSK-E 50	2,5 – 16	126,5	50
E63.15.13	HSK-E 63	1,0 – 13	123,5	50
E63.15.16	HSK-E 63	2,5 – 16	129,0	50

Hinweis: Hohe Präzision und Rundlaufgenauigkeit von ≤ 0,03 mm. Sichere Spannung des Werkzeuges durch mechanische Spannkraftverstärkung. Kein selbständiges Lösen der Spannung während der Bearbeitung bei Links- oder Rechtslauf, sowie bei Spindelstop. Spannen und Lösen mit Sechskantschlüssel.

Note: High precision and accurate concentricity of ≤ 0.03 mm. Secure gripping of the tool through mechanical amplification of the clamping force. No automatic slackening of the clamping force while machining with either clockwise or counter clockwise rotation or on spindle stop. Clamping and releasing effected by means of an Allen wrench.

Observation: Précision élevée et exactitude de circularité de ≤ 0,03 mm. Serrage sûr de l'outil grâce à l'amplification de la force de serrage. Pas de desserrage intempestif en cours d'usinage lors de la rotation la gauche ou la droite, de même qu'en cas d'arrêt de la broche. Serrage et desserrage en utilisant un clé sur à fourche.

Lieferumfang: Mit Spannschlüssel

Delivery: With wrench

Livraison: Avec clé de serrage

Bohrstangenrohlinge

Boring bar blanks
Barres d'alésage

DIN 69893-5 HSK E



Verwendung:
Zur Herstellung von Sonderwerkzeugen.

Application:
For the manufacturing of special tools.

Application:
Pour la fabrication d'outils spéciaux.

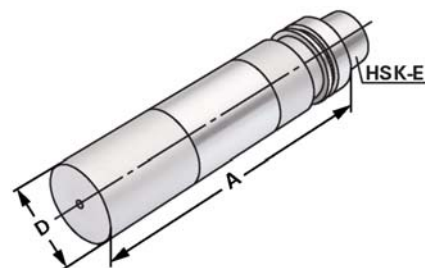

Bestell-Nr. Order no. Référence	HSK	A	D
E25.17.30	HSK-E 25	40	30,0
E32.17.32	HSK-E 32	100	32,5
E40.17.40	HSK-E 40	125	40,5
E50.17.50	HSK-E 50	125	50,5
E63.17.63	HSK-E 63	250	63,5

Ausführung: Steilkegel und Bund gehärtet und geschliffen. Schaft weich zur weiteren Bearbeitung.

Version: Cone and flange hardened and grinded. Soft body for later processing.

Version: Cône et collerette durcis et rectifiés. Corps doux pour un usinage ultérieur.



Verwendung:

Zur Aufnahme von Werkzeugen mit Zylinderschaft nach DIN 1835 Form A+B+E und DIN 6535 Form HA+HB+HE (größer Ø 20 mm nur mit Reduzierung).

Application:

For mounting straight-shank tools acc. DIN 1835 form A+B+E and DIN 6535 form HA+HB+HE (larger than dia. 20 mm only with reduction sleeve).

Application:

Pour le serrage d'outils avec queue cylindrique suivant DIN 1835 forme A+B+E et DIN 6535 forme HA+HB+HE (à partir de dia. 20 mm seulement avec réduction).

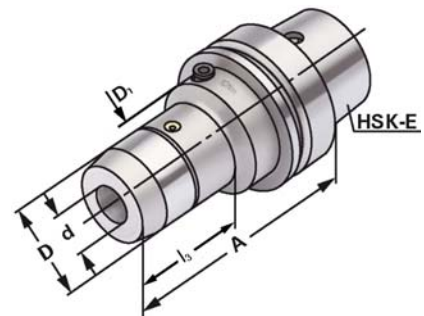

G 6,3 15.000 min⁻¹

≤ 0,003

INFO → 10.03

Bestell-Nr. Order no. Référence	HSK	d	A	D	D ₁	l ₁	l ₂	l ₃
E25.H06	HSK-E 25	6	70	26	20	37	10	38
E25.H08	HSK-E 25	8	80	28	20	37	10	-
E25.H10	HSK-E 25	10	85	30	20	42	10	-
E25.H12	HSK-E 25	12	90	32	20	47	10	-
E32.H06	HSK-E 32	6	80	26	26	37	10	60
E32.H08	HSK-E 32	8	80	28	26	37	10	-
E32.H10	HSK-E 32	10	85	30	26	42	10	-
E32.H12	HSK-E 32	12	90	32	26	47	10	-
E40.H06	HSK-E 40	6	80	26	34	37	10	35
E40.H08	HSK-E 40	8	80	28	34	37	10	36
E40.H10	HSK-E 40	10	85	30	34	42	10	41
E40.H12	HSK-E 40	12	90	32	34	47	10	47
E40.H14	HSK-E 40	14	90	34	34	47	10	70
E40.H16	HSK-E 40	16	100	38	34	52	10	-
E40.H20	HSK-E 40	20	100	42	34	52	10	-
E50.H06	HSK-E 50	6	80	26	42	37	10	54
E50.H08	HSK-E 50	8	80	28	42	37	10	54
E50.H10	HSK-E 50	10	85	30	42	42	10	59
E50.H12	HSK-E 50	12	90	32	42	47	10	64
E50.H14	HSK-E 50	14	90	34	42	47	10	64
E50.H16	HSK-E 50	16	95	38	42	52	10	69
E50.H18	HSK-E 50	18	95	40	42	52	10	69
E50.H20	HSK-E 50	20	100	42	42	52	10	74

Lieferumfang: Mit Spannschlüssel

Delivery: With wrench

Livraison: Avec clé de serrage

l₁ = max. Einstecktiefe

l₁ = max. clamping depth

l₁ = max. profondeur d'insertion

l₂ = max. Verstellweg

l₂ = max. length adjustment range

l₂ = max. course de réglage



Hydro-Dehnspannfutter

Hydraulic expansion chucks

Mandrins expansibles hydrauliques

DIN 69893-5 HSK E



Verwendung:

Zur Aufnahme von Werkzeugen mit Zylinderschaft nach DIN 1835 Form A+B+E und DIN 6535 Form HA+HB+HE (größerer Ø 20 mm nur mit Reduzierung).

Application:

For mounting straight-shank tools acc. DIN 1835 form A+B+E and DIN 6535 form HA+HB+HE (larger than dia. 20 mm only with reduction sleeve).

Application:

Pour le serrage d'outils avec queue cylindrique suivant DIN 1835 forme A+B+E et DIN 6535 forme HA+HB+HE (à partir de dia. 20 mm seulement avec réduction).

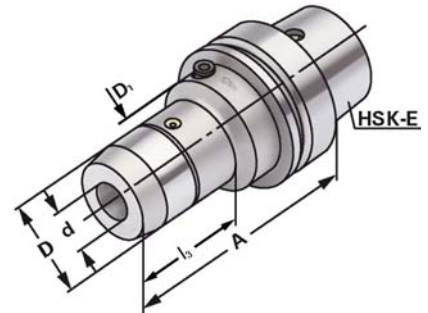

G 6,3 15.000 min⁻¹

≤ 0,003

INFO → 10.03

Bestell-Nr. Order no. Référence	HSK	d	A	D	D ₁	l ₁	l ₂	l ₃
E63.H06	HSK-E 63	6	80	26	50	37	10	33
E63.H08	HSK-E 63	8	80	28	50	37	10	33,5
E63.H10	HSK-E 63	10	85	30	50	42	10	39
E63.H12	HSK-E 63	12	90	32	50	47	10	44,5
E63.H14	HSK-E 63	14	90	34	50	47	10	46
E63.H16	HSK-E 63	16	95	38	50	52	10	51,5
E63.H18	HSK-E 63	18	95	40	50	52	10	52
E63.H20	HSK-E 63	20	100	42	50	52	10	58

Lieferumfang: Mit Spannschlüssel

Delivery: With wrench

Livraison: Avec clé de serrage

l₁ = max. Einstecktiefe

l₁ = max. clamping depth

l₁ = max. profondeur d'insertion

l₂ = max. Verstellweg

l₂ = max. length adjustment range

l₂ = max. course de réglage



7.64–7.65

Schrumpffutter zum Spannen von HM und HSS Werkzeugschäften

DIN 69893-5 HSK E

Shrink chucks for mounting of solid carbide and HSS-tool shanks

Mandrins de frettage pour le serrage de queues d'outils carbures de type HM et HSS



Verwendung:
Zur Aufnahme von Werkzeugen mit
Zylinderschaft.

Application:
For mounting straight-shank tools.

Application:
Pour le serrage d'outils avec queue
cylindrique.

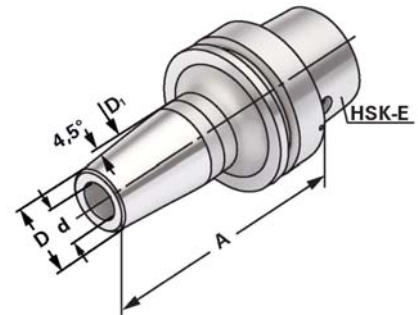

G 6,3 15.000 min⁻¹

≤ 0,003

Bestell-Nr. Order no. Référence	HSK	d	A	D	D ₁	l ₁	l ₂
E25.70.03	HSK-E 25	3	40	11	15	10	–
E25.70.04	HSK-E 25	4	40	16	22	20	–
E25.70.05	HSK-E 25	5	50	16	22	20	–
E25.70.06	HSK-E 25	6	50	21	26	36	–
E25.70.08	HSK-E 25	8	50	21	26	36	–
E25.70.10	HSK-E 25	10	50	21	26	42	–
E25.70.12	HSK-E 25	12	50	24	26	47	–
E32.70.03	HSK-E 32	3	70	11	15	10	–
E32.70.04	HSK-E 32	4	70	16	22	20	5
E32.70.05	HSK-E 32	5	70	16	22	20	5
E32.70.06	HSK-E 32	6	70	21	26	36	10
E32.70.08	HSK-E 32	8	70	21	26	36	10
E32.70.10	HSK-E 32	10	70	24	26	42	10
E32.70.12	HSK-E 32	12	80	24	26	47	10
E32.70.04.1	HSK-E 32	4	160	14	21	10	5
E32.70.05.1	HSK-E 32	5	160	16	24	20	5
E32.70.06.1	HSK-E 32	6	160	21	27	36	5
E32.70.08.1	HSK-E 32	8	160	21	27	36	10
E32.70.10.1	HSK-E 32	10	160	24	32	41	10
E32.70.12.1	HSK-E 32	12	160	24	32	47	10
E40.70.03 *	HSK-E 40	3	75	11	15	10	–
E40.70.04 *	HSK-E 40	4	80	16	22	20	5
E40.70.05 *	HSK-E 40	5	80	16	22	20	5
E40.70.06	HSK-E 40	6	80	21	27	36	10
E40.70.08	HSK-E 40	8	80	21	27	36	10
E40.70.10	HSK-E 40	10	80	24	32	42	10
E40.70.12	HSK-E 40	12	90	24	32	47	10
E40.70.14	HSK-E 40	14	90	27	34	47	10
E40.70.16	HSK-E 40	16	90	27	34	50	10

Hinweis: Aufnahme für Induktiv-, Kontakt- und Heißluftschumpfgeräte geeignet.
Schafttoleranz bei Ø 3, 4 und 5 mm = h₄, bei Ø 6–Ø 32 mm = h₆

Note: Toolholders suitable for induction-, contact- and hot air shrink units.
Ø 3, 4, 5 with h₄-tolerance and Ø 6–Ø 32 with h₆-tolerance

Observation: Porte-outils convenables pour machines à fretter par induction-,
par contact-, ou par air chaud.
Ø 3, 4, 5 avec h₄-tolerance et Ø 6–Ø 32 avec h₆-tolerance

l₁ = max. Einstecktiefe
l₁ = max. clamping depth
l₁ = max. profondeur d'insertion
l₂ = max. Verstellweg
l₂ = max. length adjustment range
l₂ = max. course de réglage

Schrumpffutter zum Spannen von HM und HSS Werkzeugschäften

DIN 69893-5 HSK E



Shrink chucks for mounting of solid carbide and HSS-tool shanks

Mandrins de frettage pour le serrage de queues d'outils carbures de type HM et HSS



Verwendung:

Zur Aufnahme von Werkzeugen mit Zylinderschaft.

Application:

For mounting straight-shank tools.

Application:

Pour le serrage d'outils avec queue cylindrique.

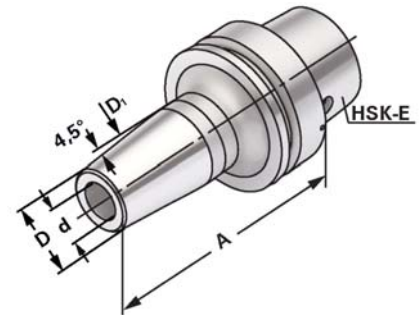

G 6,3 15.000 min⁻¹

≤ 0,003

Bestell-Nr. Order no. Référence	HSK	d	A	D	D ₁	l ₁	l ₂
E40.70.06.1	HSK-E 40	6	160	21	27	36	10
E40.70.08.1	HSK-E 40	8	160	21	27	36	10
E40.70.10.1	HSK-E 40	10	160	24	32	41	10
E40.70.12.1	HSK-E 40	12	160	24	32	47	10
E40.70.14.1	HSK-E 40	14	160	27	34	47	10
E40.70.16.1	HSK-E 40	16	160	27	34	50	10
E50.70.03	HSK-E 50	3	80	11	15	10	–
E50.70.04	HSK-E 50	4	80	16	22	20	5
E50.70.05	HSK-E 50	5	80	16	22	20	5
E50.70.06	HSK-E 50	6	80	21	27	36	10
E50.70.08	HSK-E 50	8	80	21	27	36	10
E50.70.10	HSK-E 50	10	85	24	32	42	10
E50.70.12	HSK-E 50	12	90	24	32	47	10
E50.70.14	HSK-E 50	14	90	27	34	47	10
E50.70.16	HSK-E 50	16	95	27	34	50	10
E50.70.18	HSK-E 50	18	95	33	42	50	10
E50.70.20	HSK-E 50	20	100	33	42	52	10
E50.70.03.1	HSK-E 50	3	120	11	21	10	–
E50.70.04.1	HSK-E 50	4	120	14	21	10	5
E50.70.05.1	HSK-E 50	5	120	16	24	20	5
E50.70.06.1	HSK-E 50	6	120	21	27	36	10
E50.70.08.1	HSK-E 50	8	120	21	27	36	10
E50.70.10.1	HSK-E 50	10	120	24	32	42	10
E50.70.12.1	HSK-E 50	12	120	24	32	47	10
E50.70.14.1	HSK-E 50	14	120	27	34	47	10
E50.70.16.1	HSK-E 50	16	120	27	34	50	10
E50.70.18.1	HSK-E 50	18	120	33	42	50	10
E50.70.20.1	HSK-E 50	20	120	33	42	52	10

Für Ø 3, 4 und 5 mm nur Hartmetallschäfte verwenden!

For Ø 3, 4 and 5 mm only solid carbide tool shanks must be used!

Pour Ø 3, 4 et 5 mm il faut seulement utiliser de queues d'outils carbures de type HM!

Hinweis: Aufnahme für Induktiv-, Kontakt- und Heißluftschumpfgeräte geeignet. Schafttoleranz bei Ø 3, 4 und 5 mm = h₄, bei Ø 6–Ø 32 mm = h₆

Note: Toolholders suitable for induction-, contact- and hot air shrink units. Ø 3, 4, 5 with h₄-tolerance and Ø 6–Ø 32 with h₆-tolerance

Observation: Porte-outils convenables pour machines à fretter par induction-, par contact-, ou par air chaud. Ø 3, 4, 5 avec h₄-tolerance et Ø 6–Ø 32 avec h₆-tolerance

l₁ = max. Einstecktiefe

l₁ = max. clamping depth

l₁ = max. profondeur d'insertion

l₂ = max. Verstellweg

l₂ = max. length adjustment range

l₂ = max. course de réglage

Schrumpffutter zum Spannen von HM und HSS Werkzeugschäften

DIN 69893-5 HSK E

Shrink chucks for mounting of solid carbide and HSS-tool shanks

Mandrins de frettage pour le serrage de queues d'outils carbures de type HM et HSS



Verwendung:
Zur Aufnahme von Werkzeugen mit
Zylinderschaft.

Application:
For mounting straight-shank tools.

Application:
Pour le serrage d'outils avec queue
cylindrique.

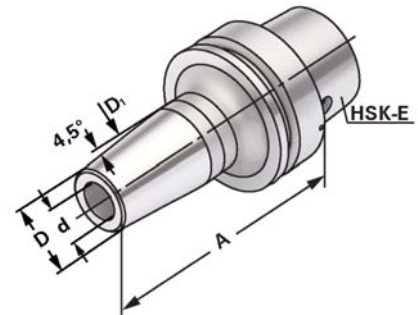

G 6,3 15.000 min⁻¹

≤ 0,003

Bestell-Nr. Order no. Référence	HSK	d	A	D	D ₁	l ₁	l ₂
E50.70.03.2	HSK-E 50	3	160	11	21	10	–
E50.70.04.2	HSK-E 50	4	160	14	21	10	5
E50.70.05.2	HSK-E 50	5	160	16	24	20	5
E50.70.06.2	HSK-E 50	6	160	21	27	36	10
E50.70.08.2	HSK-E 50	8	160	21	27	36	10
E50.70.10.2	HSK-E 50	10	160	24	32	41	10
E50.70.12.2	HSK-E 50	12	160	24	32	47	10
E50.70.14.2	HSK-E 50	14	160	27	34	47	10
E50.70.16.2	HSK-E 50	16	160	27	34	50	10
E50.70.18.2	HSK-E 50	18	160	33	42	50	10
E50.70.20.2	HSK-E 50	20	160	33	42	52	10
<hr/>							
E63.70.03	HSK-E 63	3	80	11	15	10	–
E63.70.04	HSK-E 63	4	80	14	22	20	5
E63.70.05	HSK-E 63	5	80	16	22	20	5
E63.70.06	HSK-E 63	6	80	21	27	36	10
E63.70.08	HSK-E 63	8	80	21	27	36	10
E63.70.10	HSK-E 63	10	85	24	32	41	10
E63.70.12	HSK-E 63	12	90	24	32	47	10
E63.70.14	HSK-E 63	14	90	27	34	47	10
E63.70.16	HSK-E 63	16	95	27	34	50	10
E63.70.18	HSK-E 63	18	95	33	42	50	10
E63.70.20	HSK-E 63	20	100	33	42	52	10
E63.70.25	HSK-E 63	25	115	44	53	58	10
E63.70.32	HSK-E 63	32	120	44	53	62	10

Für Ø 3, 4 und 5 mm nur Hartmetallschäfte verwenden!

For Ø 3, 4 and 5 mm only solid carbide tool shanks must be used!

Pour Ø 3, 4 et 5 mm il faut seulement utiliser de queues d'outils carbures de type HM!

Hinweis: Aufnahme für Induktiv-, Kontakt- und Heißluftschumpfgeräte geeignet.
Schafttoleranz bei Ø 3, 4 und 5 mm = h₄, bei Ø 6–Ø 32 mm = h₆

Note: Toolholders suitable for induction-, contact- and hot air shrink units.
Ø 3, 4, 5 with h₄-tolerance and Ø 6–Ø 32 with h₆-tolerance

Observation: Porte-outils convenables pour machines à fretter par induction-,
par contact-, ou par air chaud.
Ø 3, 4, 5 avec h₄-tolerance et Ø 6–Ø 32 avec h₆-tolerance

l₁ = max. Einstecktiefe

l₁ = max. clamping depth

l₁ = max. profondeur d'insertion

l₂ = max. Verstellweg

l₂ = max. length adjustment range

l₂ = max. course de réglage



Schrumpffutter zum Spannen von HM und HSS Werkzeugschäften

DIN 69893-5 HSK E



Shrink chucks for mounting of solid carbide and HSS-tool shanks

Mandrins de frettage pour le serrage de queues d'outils carbures de type HM et HSS



Verwendung:
Zur Aufnahme von Werkzeugen mit
Zylinderschaft.

Application:
For mounting straight-shank tools.

Application:
Pour le serrage d'outils avec queue
cylindrique.

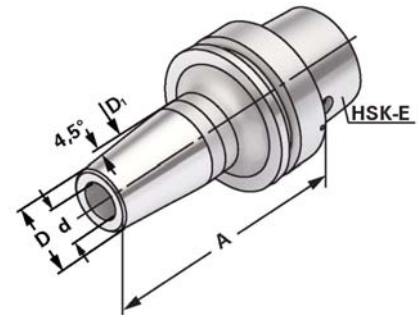

G 6,3 15.000 min⁻¹

≤ 0,003

Bestell-Nr. Order no. Référence	HSK	d	A	D	D ₁	l ₁	l ₂
E63.70.04.1	HSK-E 63	4	120	14	21	10	5
E63.70.06.1	HSK-E 63	6	120	21	27	36	10
E63.70.08.1	HSK-E 63	8	120	21	27	36	10
E63.70.10.1	HSK-E 63	10	120	24	32	41	10
E63.70.12.1	HSK-E 63	12	120	24	32	47	10
E63.70.16.1	HSK-E 63	16	120	27	34	50	10
E63.70.03.2	HSK-E 63	3	160	11	21	10	–
E63.70.04.2	HSK-E 63	4	160	14	21	10	5
E63.70.05.2	HSK-E 63	5	160	16	24	20	5
E63.70.06.2	HSK-E 63	6	160	21	27	36	10
E63.70.08.2	HSK-E 63	8	160	21	27	36	10
E63.70.10.2	HSK-E 63	10	160	24	32	41	10
E63.70.12.2	HSK-E 63	12	160	24	32	47	10
E63.70.14.2	HSK-E 63	14	160	27	34	47	10
E63.70.16.2	HSK-E 63	16	160	27	34	50	10
E63.70.18.2	HSK-E 63	18	160	33	42	50	10
E63.70.20.2	HSK-E 63	20	160	33	42	52	10
E63.70.25.2	HSK-E 63	25	160	44	42	58	10

Für Ø 3, 4 und 5 mm nur Hartmetallschäfte verwenden!

For Ø 3, 4 and 5 mm only solid carbide tool shanks must be used!

Pour Ø 3, 4 et 5 mm il faut seulement utiliser de queues d'outils carbures de type HM!

Hinweis: Aufnahme für Induktiv-, Kontakt- und Heißluftschumpfgeräte geeignet.
Schafttoleranz bei Ø 3, 4 und 5 mm = h₄, bei Ø 6–Ø 32 mm = h₆

Note: Toolholders suitable for induction-, contact- and hot air shrink units.
Ø 3, 4, 5 with h₄-tolerance and Ø 6–Ø 32 with h₆-tolerance

Observation: Porte-outils convenables pour machines à fretter par induction-,
par contact-, ou par air chaud.
Ø 3, 4, 5 avec h₄-tolerance et Ø 6–Ø 32 avec h₆-tolerance

l₁ = max. Einstecktiefe

l₁ = max. clamping depth

l₁ = max. profondeur d'insertion

l₂ = max. Verstellweg

l₂ = max. length adjustment range

l₂ = max. course de réglage



Werkzeugaufnahmen DIN 69893-6 Form F

Toolholders DIN 69893-6 form F

Porte-outils DIN 69893-6 forme F

Vorgewuchtet

Pre-balanced
Pré-équilibré

G 6,3 15.000 min⁻¹

G 2,5 Feinwuchten gegen Aufpreis

G 2,5 Fine balancing at extra charge

G 2,5 Equilibrage fin contre un supplément

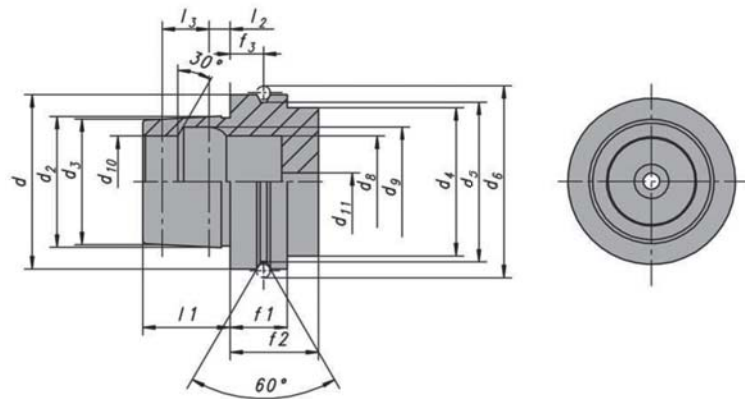

d ₁	d ₂	d ₃	d ₄	d ₅ -0,1	d ₆ -0,1	d ₈ ^{H10}	d ₉ ^{H11}	d ₁₀	f ₁ -0,1	f ₂ min.	f ₃ ^{±0,1}	l ₁ -0,2	l ₂	l ₃
50	30 ^{+0,007} _{+0,005}	29,05 ^{+0,005} _{+0,003}	42	43	59,3	21	25,5	23	26	42	18	20	4	9,5
65	38 ^{+0,009} _{+0,006}	36,90 ^{+0,006} _{+0,003}	53	55	72,3	26	32	29	26	42	18	25	5	11

Werkstoff: Legierter Einsatzstahl mit einer Zugfestigkeit im Kern von min. 1000 N/mm². Einsatzgehärtet HRC 60 ± 2 (HV 700 ± 50), Härtetiefe 0,8 mm ± 0,2 mm, brüniert und präzisionsgeschliffen.

Genauigkeit: Kegelwinkel – Toleranzqualität < AT 3 nach DIN 7187.

Material: Alloyed case-hardened steel, tensile core strength of min. 1000 N/mm². Case hardened HRC 60 ± 2 (HV 700 ± 50), hardening depth 0.8 mm ± 0.2 mm, black-finished and precisely grinded.

Accuracy: Quality of taper < AT 3 according to DIN 7187.

Matière: Acier de cémentation allié. Résistance à la traction dans le noyau de min 1000 N/mm². Cémentation à HRC 60 ± 2 (HV 700 ± 50), profondeur de cémentation 0,8 mm ± 0,2 mm, bruni et rectifié précisément.

Précision: Qualité du cône < AT 3 suivant DIN 7187.



Spannfutter für Spannzangen DIN 6499 (ISO 15488) System ER

DIN 69893-6 HSK F

Collet chucks for collets DIN 6499 (ISO 15488) ER-system

Mandrins à pinces pour pinces DIN 6499 (ISO 15488) système ER



Verwendung:

Zur Aufnahme von Werkzeugen mit Zylinderschaft in Spannzangen.

Application:

For mounting straight-shank tools in collets.

Application:

Pour le serrage d'outils avec queue cylindrique dans des pinces de serrage.

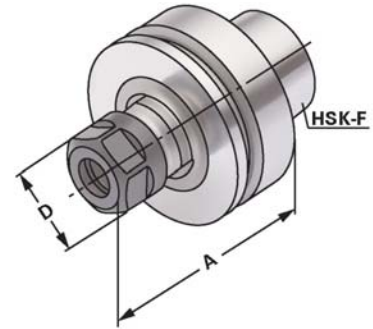

G 6,3 15.000 min⁻¹

≤ 0,003

INFO → 10.03

Bestell-Nr. Order no. Référence	HSK	Spannbereich Capacity d Capacité	A	D
F40.02.10	HSK-F 40	1 – 10 (ER 16)	60	28
F40.02.16	HSK-F 40	1 – 16 (ER 25)	60	50
F50.02.16	HSK-F 50	1 – 16 (ER 25)	70	42
F50.02.20	HSK-F 50	2 – 20 (ER 32)	80	50
F50.02.26	HSK-F 50	3 – 26 (ER 40)	80	63
F63.02.10	HSK-F 63	1 – 10 (ER 16)	60	28
F63.02.16	HSK-F 63	1 – 16 (ER 25)	70	42
F63.02.20	HSK-F 63	2 – 20 (ER 32)	90	50
F63.02.26	HSK-F 63	3 – 26 (ER 40)	75	63
F63.02.10.1	HSK-F 63	1 – 10 (ER 16)	100	28
F63.02.20.1	HSK-F 63	2 – 20 (ER 32)	160	50
F63.02.26.1	HSK-F 63	3 – 26 (ER 40)	90	63
F63.02.10.2	HSK-F 63	1 – 10 (ER 16)	160	28
F63.02.26.2	HSK-F 63	3 – 26 (ER 40)	125	63
F63.02.26.3	HSK-F 63	3 – 26 (ER 40)	160	63

Lieferumfang: Mit gewuchteter Spannmutter

Delivery: With balanced clamping nut

Livraison: Avec écrou de serrage équilibré



Fräseraufnahmen DIN 6359 für Zylinderschäfte DIN 1835-B DIN 69893-6 HSK F

End mill holders DIN 6359 for end mills DIN 1835-B

Porte-fraises DIN 6359 pour queues cylindriques DIN 1835-B



Verwendung:

Zum Spannen von zylindrischen Werkzeugschäften mit seitlicher Spannfläche nach DIN 1835 Form B (Weldon).

Application:

For mounting straight-shank tools with flat according to DIN 1835 form B (Weldon).

Application:

Pour le serrage d'outils avec queue cylindrique et avec méplat suivant DIN 1835 forme B (Weldon).

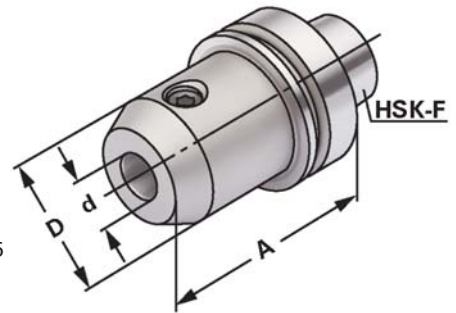

G 6,3 15.000 min⁻¹

≤ 0,003

Bestell-Nr. Order no. Référence	HSK	d ^{H4}	A	D
F63.04.06	HSK-F 63	6	65	25
F63.04.08	HSK-F 63	8	65	28
F63.04.10	HSK-F 63	10	65	35
F63.04.12	HSK-F 63	12	80	42
F63.04.14	HSK-F 63	14	80	44
F63.04.16	HSK-F 63	16	80	48
F63.04.18	HSK-F 63	18	80	48
F63.04.20	HSK-F 63	20	80	52
F63.04.25	HSK-F 63	25	110	65
F63.04.32	HSK-F 63	32	110	72

Hinweis: Ab d = 25 mit zwei Spannschrauben

Note: From d = 25 on two clamping screws

Observation: A partir de d = 25 avec deux vis de serrage

Lieferumfang: Mit Spannschraube

Delivery: With clamping screw

Livraison: Avec vis de serrage



Verwendung:

Zum Spannen von zylindrischen Werkzeugschäften mit geneigter Spannfläche nach DIN 1835 Form E (Whistle Notch).

Application:

For mounting straight-shank tools and inclined flat according to DIN 1835 form E (Whistle Notch).

Application:

Pour le serrage d'outils avec queue cylindrique et avec méplat incliné suivant DIN 1835 forme E (Whistle Notch).

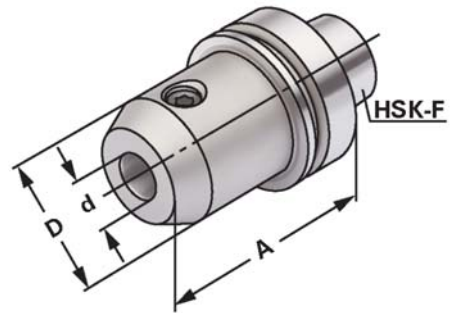

G 6,3 15.000 min⁻¹

≤ 0,003

Bestell-Nr. Order no. Référence	HSK	d ^{H4}	A	D
F63.05.06	HSK-F 63	6	100	25
F63.05.08	HSK-F 63	8	100	28
F63.05.10	HSK-F 63	10	100	35
F63.05.12	HSK-F 63	12	100	42
F63.05.14	HSK-F 63	14	100	44
F63.05.16	HSK-F 63	16	100	48
F63.05.18	HSK-F 63	18	100	48
F63.05.20	HSK-F 63	20	100	52
F63.05.25	HSK-F 63	25	120	65
F63.05.32	HSK-F 63	32	120	72

Hinweis: Ab d = 25 mit zwei Spannschrauben

Note: From d = 25 on two clamping screws

Observation: A partir de d = 25 avec deux vis de serrage

Lieferumfang: Mit Spannschraube und axialer Verstellechraube

Delivery: With clamping screw and axial adjustment bolt

Livraison: Avec vis de serrage et vis de butée axiale

Zwischenhülsen für MK mit Austreibblappen DIN 6383

Adaptor sleeves for MT with tang DIN 6383

Douilles de réduction pour CM à tenon DIN 6383

DIN 69893-6 HSK F



Verwendung:

Zur Aufnahme von Werkzeugen mit Morsekegelschaft und Austreibblappen nach DIN 228-1 Form B.

Application:

For mounting tools with Morse taper shank and tang according to DIN 228-1 form B.

Application:

Pour le serrage d'outils avec queue cône Morse et tenon suivant DIN 228-1 forme B.

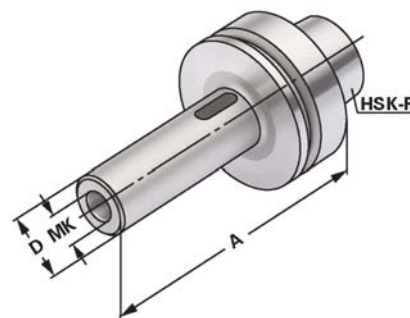

G 6,3 15.000 min⁻¹

≤ 0,005

Bestell-Nr. Order no. Référence	HSK	MK	A	D
F63.07.01	HSK-F 63	1	100	25
F63.07.02	HSK-F 63	2	120	32
F63.07.03	HSK-F 63	3	140	40
F63.07.04	HSK-F 63	4	160	48



Quernut-Aufsteckfräserdorne DIN 6357 mit vergrößerter Anlagefläche

DIN 69893-6 HSK F

Shell mill holders DIN 6357 with enlarged contact face

Porte-fraises à trou lisse DIN 6357 avec face de contact élargie



Verwendung:

Zur Aufnahme von Messerköpfen und Fräsern mit Quernut.

Application:

For mounting milling cutters with transversal groove.

Application:

Pour le serrage de fraises à rainure transversale.

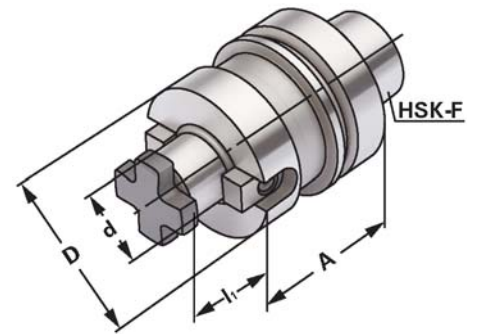

G 6,3 15.000 min⁻¹

≤ 0,005

Bestell-Nr. Order no. Référence	HSK	d _{h6}	A	l	D
F63.11.16	HSK-F 63	16	50	17	50
F63.11.22	HSK-F 63	22	50	19	50
F63.11.27	HSK-F 63	27	60	21	60
F63.11.32	HSK-F 63	32	60	24	78
F63.11.22.1	HSK-F 63	22	100	19	50
F63.11.27.1	HSK-F 63	27	100	21	60
F63.11.32.1	HSK-F 63	32	100	24	78
F63.11.40.1	HSK-F 63	40	100	27	89
F63.11.22.2	HSK-F 63	22	160	19	50

d = 40:

Für große Planfräser mit vier zusätzlichen Gewindebohrungen nach DIN 2079.

For large diameter face mill cutters with four additional threaded holes according to DIN 2079.

Pour fraises à surfacer à grands diamètres avec quatre trous taraudés additionnels suivant DIN 2079.

Lieferumfang: Mit Mitnehmersteinen und Kreuzschraube.

Delivery: With drivers and cross head retaining screw.

Livraison: Avec tenons et une vis cruciforme.



CNC-Bohrfutter für Rechts- und Linkslauf

CNC-Drill chucks for clockwise and counter clockwise rotation

Mandrins de perçage CNC pour rotation gauche-droite

DIN 69893-6 HSK F



Verwendung:

Zur Aufnahme von Werkzeugen mit Zylinderschaft.

Application:

For mounting tools with straight shanks.

Application:

Pour le serrage d'outils avec queue cylindrique.

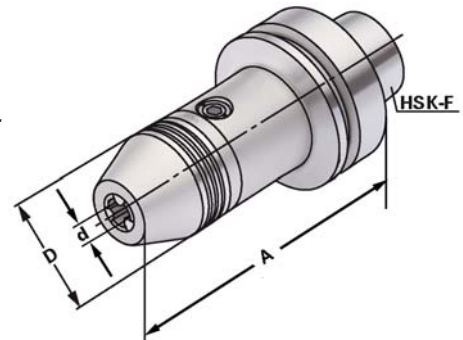

G 6,3 15.000 min⁻¹

≤ 0,03

INFO → 10.03

Bestell-Nr. Order no. Référence	HSK	Spannbereich Capacity Capacité	A	D
F63.15.13	HSK-F 63	1,0 – 13	123,5	50
F63.15.16	HSK-F 63	2,5 – 16	129,5	50

Hinweis: Hohe Präzision und Rundlaufgenauigkeit von $\leq 0,03$ mm. Sichere Spannung des Werkzeuges durch mechanische Spannkraftverstärkung. Kein selbständiges Lösen der Spannung während der Bearbeitung bei Links- oder Rechtslauf, sowie bei Spindelstop. Spannen und Lösen mit Sechskantschlüssel.

Note: High precision and accurate concentricity of ≤ 0.03 mm. Secure gripping of the tool through mechanical amplification of the clamping force. No automatic slackening of the clamping force while machining with either clockwise or counter clockwise rotation or on spindle stop. Clamping and releasing effected by means of an Allen wrench.

Observation: Précision élevée et exactitude de circularité de $\leq 0,03$ mm. Serrage sûr de l'outil grâce à l'amplification de la force de serrage. Pas de desserrage intempestif en cours d'usinage lors de la rotation la gauche ou la droite, de même qu'en cas d'arrêt de la broche. Serrage et desserrage en utilisant un clé sur à fourche.

Lieferumfang: Mit Spannschlüssel

Delivery: With wrench

Livraison: Avec clé de serrage

Bohrstangenrohlinge

Boring bar blanks
Barres d'alésage

DIN 69893-6 HSK F



Verwendung:
Zur Herstellung von Sonderwerkzeugen.

Application:
For the manufacturing of special tools.

Application:
Pour la fabrication d'outils spéciaux.

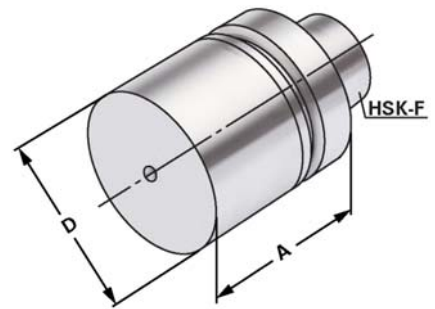

Bestell-Nr. Order no. Référence	HSK	A	D
F63.17.63	HSK-F 63	125	63
F63.17.63.1	HSK-F 63	250	63

Ausführung: Steilkegel und Bund gehärtet und geschliffen. Schaft weich zur weiteren Bearbeitung.

Version: Cone and flange hardened and adjusted. Soft body for later processing.

Version: Cône et collerette durcis et rectifiés. Corps doux pour un usinage ultérieur.

Kontrolldorne

Test arbors

Mandrins de contrôle

DIN 9893-6 HSK F



Verwendung:

Zur Abnahme von Werkzeugmaschinen gemäß ISO-Empfehlung R230 oder zur Überprüfung der Werkzeugspindel.

Application:

For the inspection of machine tools according to ISO recommendation R230 or for testing the tool spindle.

Application:

Pour l'inspection de machine-outils suite à la recommandation ISO R230 ou pour la vérification de la broche.

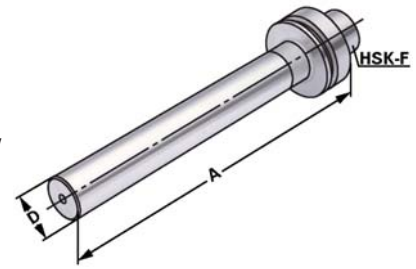

↗ ≤ 0,003

Bestell-Nr. Order no. Référence	HSK	d	A	D	l ₁	l ₂
F63.18.40	HSK-F 63	40	250	40	224	200

Holzkasten für Kontrolldorne

Wooden box for test arbors

Coffret en bois pour mandrins de contrôle



Verwendung:

Zur Aufbewahrung von Kontrolldornen.

Application:

For the storage of test arbors.

Application:

Pour la conservation de mandrins de contrôle.



Bestell-Nr. Order no. Référence	Abmessung Size Dimension	für Kegelgrößen for cones pour cônes
701.18	460 × 130 × 115	HSK 32 / 40 / 50 / 63 / 80 / 100

Schrumpffutter zum Spannen von HM und HSS Werkzeugschäften

DIN 69893-6 HSK F

Shrink chucks for mounting of solid carbide and HSS-tool shanks

Mandrins de frettage pour le serrage de queues d'outils carbures de type HM et HSS



Verwendung:
Zur Aufnahme von Werkzeugen mit
Zylinderschaft.

Application:
For mounting straight-shank tools.

Application:
Pour le serrage d'outils avec queue
cylindrique.

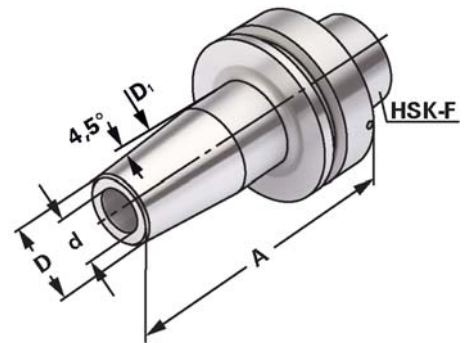

G 6,3 15.000 min⁻¹

≤ 0,003

Bestell-Nr. Order no. Référence	HSK	d	A	D	D ₁	l ₁	l ₂
F63.70.03	HSK-F 63	3	80	11	15	10	–
F63.70.04	HSK-F 63	4	80	14	22	20	5
F63.70.05	HSK-F 63	5	80	16	22	20	5
F63.70.06	HSK-F 63	6	80	21	27	36	10
F63.70.08	HSK-F 63	8	80	21	27	36	10
F63.70.10	HSK-F 63	10	95	24	32	42	10
F63.70.12	HSK-F 63	12	95	24	32	47	10
F63.70.14	HSK-F 63	14	95	27	34	47	10
F63.70.16	HSK-F 63	16	95	27	34	50	10
F63.70.18	HSK-F 63	18	95	33	42	50	10
F63.70.20	HSK-F 63	20	100	33	42	52	10
F63.70.25	HSK-F 63	25	115	44	54	58	10
F63.70.03.1	HSK-F 63	3	120	11	15	10	–
F63.70.04.1	HSK-F 63	4	120	16	22	20	5
F63.70.05.1	HSK-F 63	5	120	16	22	20	5
F63.70.06.1	HSK-F 63	6	120	21	27	36	10
F63.70.08.1	HSK-F 63	8	120	21	27	36	10
F63.70.10.1	HSK-F 63	10	120	24	32	42	10
F63.70.12.1	HSK-F 63	12	120	24	32	47	10
F63.70.14.1	HSK-F 63	14	120	27	34	47	10
F63.70.16.1	HSK-F 63	16	120	27	34	50	10
F63.70.18.1	HSK-F 63	18	120	33	42	50	10

Für Ø 3, 4 und 5 mm nur Hartmetallschäfte verwenden!

For Ø 3, 4 and 5 mm only solid carbide tool shanks must be used!

Pour Ø 3, 4 et 5 mm il faut seulement utiliser de queues d'outils carbures de type HM!

Hinweis: Aufnahme für Induktiv-, Kontakt- und Heißluftschumpfgeräte geeignet.
Schafttoleranz bei Ø 3, 4 und 5 mm = h₄, bei Ø 6–Ø 32 mm = h₆

Note: Toolholders suitable for induction-, contact- and hot air shrink units.
Ø 3, 4, 5 with h₄-tolerance and Ø 6–Ø 32 with h₆-tolerance

Observation: Porte-outils convenables pour machines à fretter par induction-,
par contact-, ou par air chaud.
Ø 3, 4, 5 avec h₄-tolerance et Ø 6–Ø 32 avec h₆-tolerance

l₁ = max. Einstecktiefe

l₁ = max. clamping depth

l₁ = max. profondeur d'insertion

l₂ = max. Verstellweg

l₂ = max. length adjustment range

l₂ = max. course de réglage



Schrumpffutter zum Spannen von HM und HSS Werkzeugschäften

DIN 69893-6 HSK F



Shrink chucks for mounting of solid carbide and HSS-tool shanks

Mandrins de frettage pour le serrage de queues d'outils carbures de type HM et HSS



Verwendung:
Zur Aufnahme von Werkzeugen mit
Zylinderschaft.

Application:
For mounting straight-shank tools.

Application:
Pour le serrage d'outils avec queue
cylindrique.

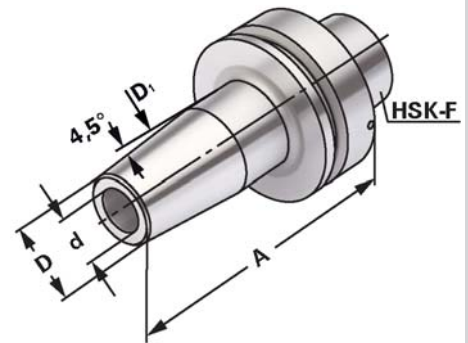

G 6,3 15.000 min⁻¹

≤ 0,003

Bestell-Nr. Order no. Référence	HSK	d	A	D	D ₁	l ₁	l ₂
F63.70.04.2	HSK-F 63	4	160	16	22	20	5
F63.70.05.2	HSK-F 63	5	160	16	22	20	5
F63.70.06.2	HSK-F 63	6	160	21	27	36	10
F63.70.08.2	HSK-F 63	8	160	21	27	36	10
F63.70.10.2	HSK-F 63	10	160	24	32	42	10
F63.70.12.2	HSK-F 63	12	160	24	32	47	10
F63.70.14.2	HSK-F 63	14	160	27	34	47	10
F63.70.16.2	HSK-F 63	16	160	27	34	50	10
F63.70.18.2	HSK-F 63	18	160	33	42	50	10
F63.70.20.2	HSK-F 63	20	160	33	42	52	10

Für Ø 3, 4 und 5 mm nur Hartmetallschäfte verwenden!

For Ø 3, 4 and 5 mm only solid carbide tool shanks must be used!

Pour Ø 3, 4 et 5 mm il faut seulement utiliser de queues d'outils carbures de type HM!

Hinweis: Aufnahme für Induktiv-, Kontakt- und Heißluftschumpfgeräte geeignet.
Schafttoleranz bei Ø 3, 4 und 5 mm = h₄, bei Ø 6–Ø 32 mm = h₆

Note: Toolholders suitable for induction-, contact- and hot air shrink units.
Ø 3, 4, 5 with h₄-tolerance and Ø 6–Ø 32 with h₆-tolerance

Observation: Porte-outils convenables pour machines à fretter par induction-,
par contact-, ou par air chaud.
Ø 3, 4, 5 avec h₄-tolerance et Ø 6–Ø 32 avec h₆-tolerance

l₁ = max. Einstecktiefe

l₁ = max. clamping depth

l₁ = max. profondeur d'insertion

l₂ = max. Verstellweg

l₂ = max. length adjustment range

l₂ = max. course de réglage



7.65

Hydro-Dehnspannfutter

Hydraulic expansion chucks

Mandrins expansibles hydrauliques

DIN 69893-6 HSK F



Verwendung:

Zur Aufnahme von Werkzeugen mit Zylinderschaft nach DIN 1835 Form A+B+E und DIN 6535 Form HA+HB+HE (größer Ø 20 mm nur mit Reduzierung).

Application:

For mounting straight-shank tools acc. DIN 1835 form A+B+E and DIN 6535 form HA+HB+HE (larger than dia. 20 mm only with reduction sleeve).

Application:

Pour le serrage d'outils avec queue cylindrique suivant DIN 1835 forme A+B+E et DIN 6535 forme HA+HB+HE (à partir de dia. 20 mm seulement avec réduction).

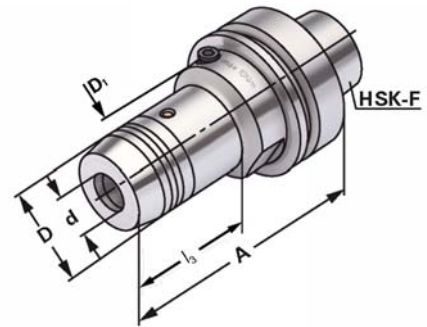

G 6,3 15.000 min⁻¹

≤ 0,003

INFO ➔ 10.03

Bestell-Nr.

Order no.

Référence

	HSK	d	A	D	D ₁	l ₁	l ₂	l ₃
F63.H06	HSK-F 63	6	100	26	50	37	10	45
F63.H08	HSK-F 63	8	100	28	50	37	10	44
F63.H10	HSK-F 63	10	100	30	50	42	10	46
F63.H12	HSK-F 63	12	100	32	50	47	10	45,5
F63.H14	HSK-F 63	14	100	34	50	47	10	44
F63.H16	HSK-F 63	16	100	38	50	52	10	44
F63.H18	HSK-F 63	18	100	40	50	52	10	42
F63.H20	HSK-F 63	20	100	42	50	52	10	42
F63.H25	HSK-F 63	25	120	50	50	58	10	26
F63.H32	HSK-F 63	32	125	60	50	62	10	26

Lieferumfang: Mit Spannschlüssel

Delivery: With wrench

Livraison: Avec clé de serrage

l₁ = max. Einstecktiefe

l₁ = max. clamping depth

l₁ = max. profondeur d'insertion

l₂ = max. Verstellweg

l₂ = max. length adjustment range

l₂ = max. course de réglage



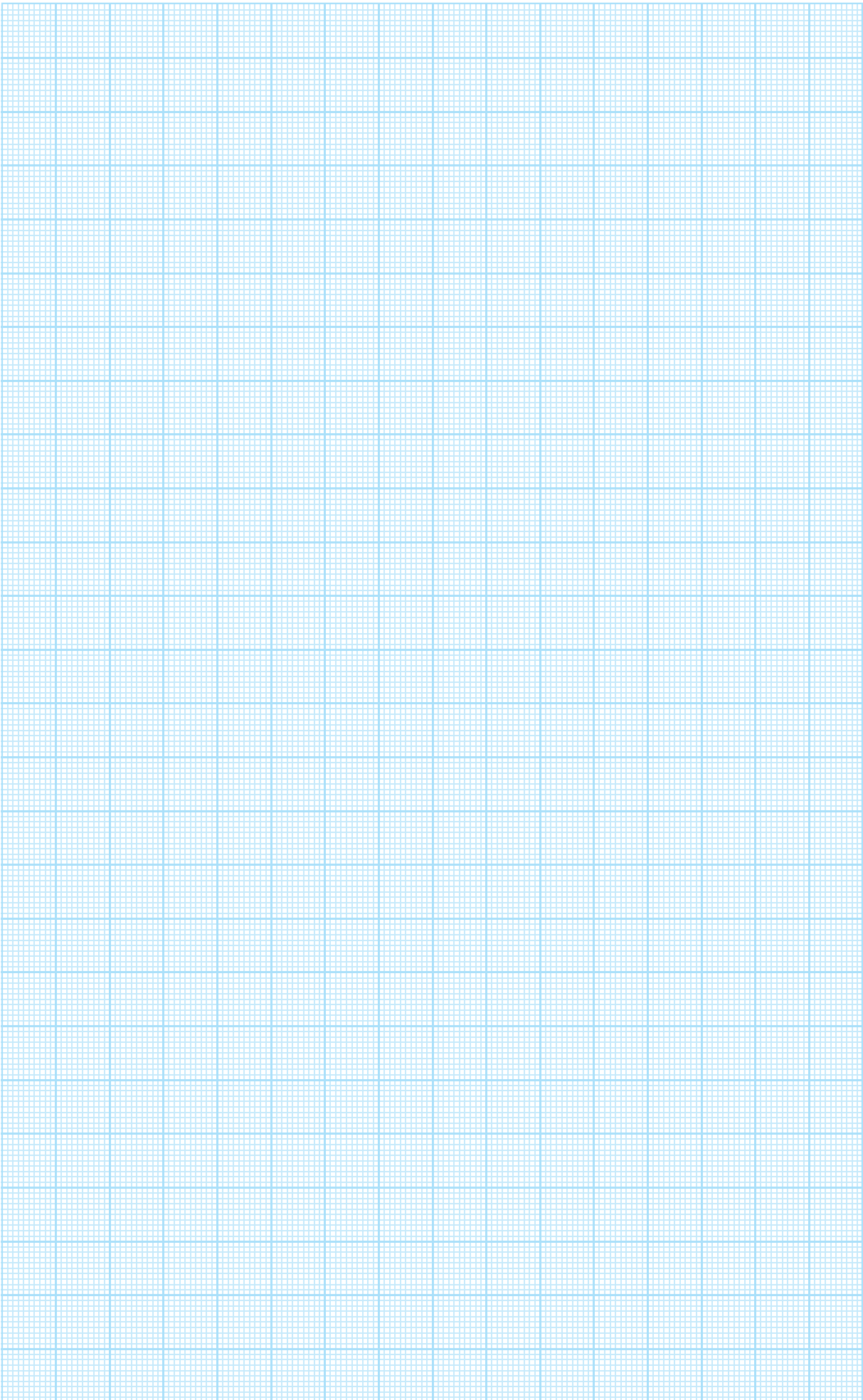

Компания "**ИНТЕРТУМАШ**" - поставщик оборудования

Kemmler в России.

Kemmler – компания, специализирующаяся на производстве отличного технологического оборудования. Направление работы – инструментальная оснастка для токарных и фрезерных станков различных типов и стандартов.



Для заказа инструмента и технических консультаций оформите заказ на нашем сайте

www.itmash.ru

Наши сотрудники оперативно свяжутся с Вами.

Вы можете присылать Ваши заявки и вопросы на электронную почту

inbox@itmash.ru

или звоните по телефону

(495) 668-13-58.

Вы также можете воспользоваться [формой заявки на сайте](#).