

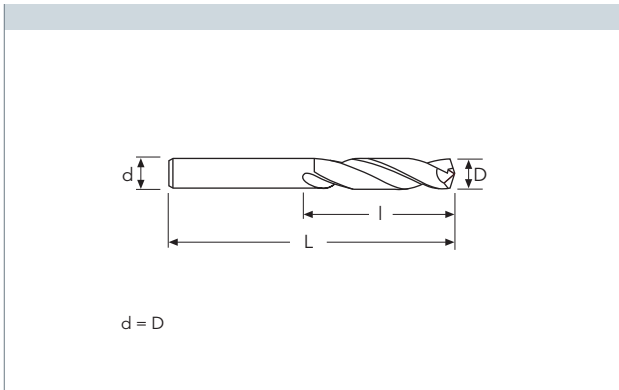

138N - 1386STI - 138NTI - 138HB - 138WB (h8)

Ø mm	1~3	3.1~6	6.1~10	10.1~18	18.1~20
tol. D µ	0 / -14	0 / -18	0 / -22	0 / -27	0 / -33



138N	1386STI	138NTI	138HB	138WB
HSS OX	HSS TiN	HSS TiN	HSS BR	HSS BR

D(h8)	I	L		Stock	Stock	Stock	Stock	Stock
mm 12.25	101	151	5	●				
12.30	101	151	5	●	●			
12.40	101	151	5	●	●			
12.50	101	151	5	●	●	●	○	○
12.60	101	151	5	●	●			
12.70	101	151	5	●	●			
12.75	101	151	5	●	●			
12.80	101	151	5	●	●			
12.90	101	151	5	●	●			
13.00	101	151	5	●	●	●	○	○
13.25	108	160	1	●				
13.50	108	160	1	●		●		
13.75	108	160	1	●				
14.00	108	160	1	●		●		
14.25	114	169	1	●				
14.50	114	169	1	●		●		
14.75	114	169	1	●				
15.00	114	169	1	●		●		
15.25	120	178	1	●				
15.50	120	178	1	●		●		
15.75	120	178	1	●				
16.00	120	178	1	●		●		
16.25	125	184	1	●				
16.50	125	184	1	●				
16.75	125	184	1	●				
17.00	125	184	1	●				
17.50	130	191	1	●				
18.00	130	191	1	●				
18.50	135	198	1	●				
19.00	135	198	1	●				
19.50	140	205	1	●				
20.00	140	205	1	●				

● stock standard ○ non-standard stock ■ stock exhaustion

- TYPHOON
- C-SD-TA
- LFTA
- SUTA
- HSS-
HSS/CO
DRILLS
- UH
RED
- MEX
ORANGE
- HF
EVO
- MEF
ENDLESS
- ALU
- MDC
- G2
- MDTA
- ULTRA
MILLS
- HSS/CO
- CARBIDE
BURRS
- PARAMETERS