

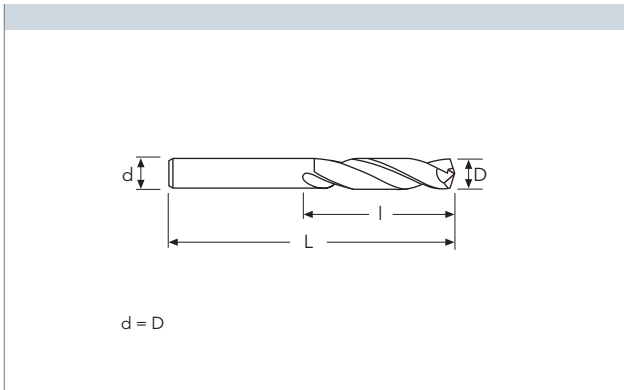

138N - 1386STI - 138NTI - 138HB - 138WB (h8)

Ø mm	1~3	3.1~6	6.1~10	10.1~18	18.1~20
tol. D µ	0 / -14	0 / -18	0 / -22	0 / -27	0 / -33



138N	1386STI	138NTI	138HB	138WB
HSS OX	HSS TiN	HSS TiN	HSS BR	HSS BR

D(h8)	I	L		Stock	Stock	Stock	Stock	Stock
mm 6.25	63	101	10	●	●	●	○	○
6.30	63	101	10	●	●	●	○	○
6.40	63	101	10	●	●	●	○	○
6.50	63	101	10	●	●	●	○	○
6.60	63	101	5	●	●	●	○	○
6.70	63	101	5	●	●	●	○	○
6.75	69	109	5	●	●	●	○	○
6.80	69	109	5	●	●	●	○	●
6.90	69	109	5	●	●	●	○	○
7.00	69	109	5	●	●	●	○	○
7.10	69	109	5	●	●	●	○	○
7.20	69	109	5	●	●	●	○	○
7.25	69	109	5	●	●	●	○	○
7.30	69	109	5	●	●	●	○	○
7.40	69	109	5	●	●	●	○	○
7.50	69	109	5	●	●	●	○	○
7.60	75	117	5	●	●	○	○	○
7.70	75	117	5	●	●	●	○	○
7.75	75	117	5	●	●	●	○	○
7.80	75	117	5	●	●	●	○	○
7.90	75	117	5	●	●	●	○	○
8.00	75	117	5	●	●	●	○	○
8.10	75	117	5	●	●	●	○	○
8.20	75	117	5	●	●	●	○	○
8.25	75	117	5	●	●	●	○	○
8.30	75	117	5	●	●	●	○	○
8.40	75	117	5	●	●	○	○	○
8.50	75	117	5	●	●	●	○	○
8.60	81	125	5	●	●	●	○	○
8.70	81	125	5	●	●	●	○	○
8.75	81	125	5	●	●	●	○	○
8.80	81	125	5	●	●	●	○	○
8.90	81	125	5	●	●	●	○	○
9.00	81	125	5	●	●	●	○	○
9.10	81	125	5	●	●	○	○	○
9.20	81	125	5	●	●	○	○	○

● stock standard ○ non-standard stock ■ stock exhaustion

- TYPHOON
- C-SD-TA
- LFTA
- SUTA
- HSS-HSS/CO DRILLS
- UH RED
- MEX ORANGE
- HF EVO
- MEF ENDLESS
- ALU
- MDC
- G2
- MDTA
- ULTRA MILLS
- HSS/CO
- CARBIDE BURRS
- PARAMETERS