

n **Vf**
PAGE 250

DIN 1897

118N - 218NVA (h8)

Ø mm	1~3	3.1~6	6.1~10	10.1~18	18.1~20
tol. D µ	0 / -14	0 / -18	0 / -22	0 / -27	0 / -33

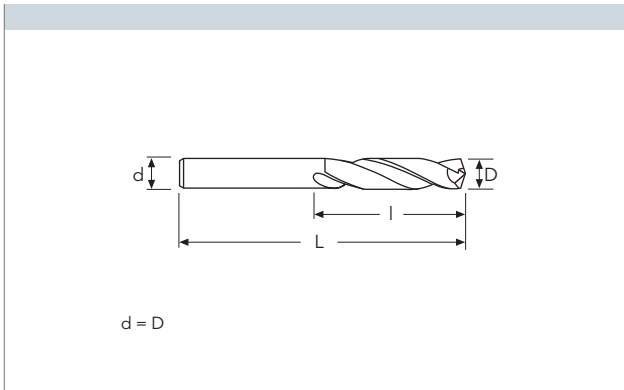

HSS	HSS/CO
OX	HT

D(h8)	I	L		Stock	Stock
mm 10.00	43	89	5	●	●
10.20	43	89	5	●	●
10.25	43	89	5	●	●
10.50	43	89	5	●	●
10.75	47	95	5	●	●
11.00	47	95	5	●	●
11.25	47	95	5	●	○
11.50	47	95	5	●	●
11.75	47	95	5	●	●
12.00	51	102	5	●	●
12.25	51	102	5	●	●
12.50	51	102	5	●	●
12.75	51	102	5	●	●
13.00	51	102	5	●	●
13.25	54	107	1	●	○
13.50	54	107	1	●	●
13.75	54	107	1	●	○
14.00	54	107	1	●	●
14.25	56	111	1	●	●
14.50	56	111	1	●	●
14.75	56	111	1	●	○
15.00	56	111	1	●	●
15.25	58	115	1	●	○
15.50	58	115	1	●	●
15.75	58	115	1	○	○
16.00	58	115	1	●	●
16.25	60	119	1		○
16.50	60	119	1		●
16.75	60	119	1		○
17.00	60	119	1		●
17.25	62	123	1		○
17.50	62	123	1		●
17.75	62	123	1		○
18.00	62	123	1		●
18.25	64	127	1		○
18.50	64	127	1		●

● stock standard ○ non-standard stock ■ stock exhaustion

- TYPHOON
- C-SD-TA
- LFTA
- SUTA
- HSS-HSS/CO DRILLS
- UH RED
- MEX ORANGE
- HF EVO
- MEF ENDLESS
- ALU
- MDC
- G2
- MDTA
- ULTRA MILLS
- HSS/CO
- CARBIDE BURRS
- PARAMETERS