

NEW

PAGE 246-247

DIN 6537K

3XD

353TA - 353HTA - 353SUH - 353ALH - 353HRC (m7)

Ø mm	1~3	3.1~6	6.1~10	10.1~18	18.1~20
tol. D µ	+12 / +2	+16 / +4	+21 / +6	+25 / +7	+29 / +8

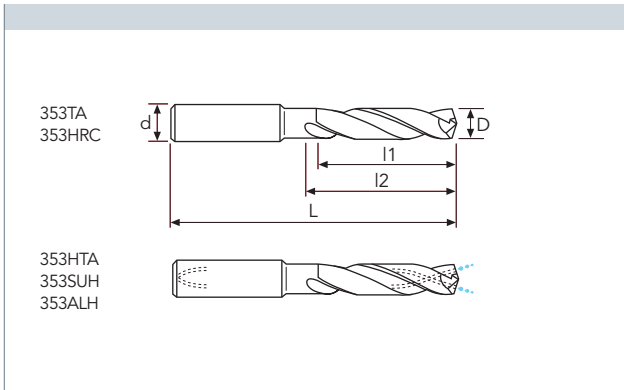

353TA	353HTA	353SUH	353ALH	353HRC
MG	MG	MG	MG	MG
PV200	PV200	PV300	LAPPED	PV1000
140°	140°	140°	140°	150°
30°	30°	30°	30°	15°

D(m7)	d(h6)	l1	l2	L	Stock	Stock	Stock	Stock	Stock
mm 10.10	12	40	55	102	●	●	●	●	●
10.20	12	40	55	102	●	●	●	●	●
10.30	12	40	55	102	●	●	●	●	●
10.40	12	40	55	102	○	●	●	●	●
10.50	12	40	55	102	●	●	●	●	●
10.60	12	40	55	102	●	●	●	●	●
10.70	12	40	55	102	○	○	●	●	●
10.80	12	40	55	102	●	●	●	○	●
10.90	12	40	55	102	○	○	●	●	●
11.00	12	40	55	102	●	●	●	●	●
11.10	12	40	55	102	○	●	●	●	●
11.20	12	40	55	102	●	●	○	○	●
11.30	12	40	55	102	●	●	○	○	●
11.40	12	40	55	102	○	○	●	●	●
11.50	12	40	55	102	●	●	●	●	●
11.60	12	40	55	102	●	●	●	●	●
11.70	12	40	55	102	●	●	●	●	●
11.80	12	40	55	102	●	●	●	○	●
11.90	12	40	55	102	●	○	●	●	●
12.00	12	40	55	102	●	●	●	●	●
12.20	14	43	60	107	●	●	●	○	●
12.50	14	43	60	107	●	●	●	○	●
12.60	14	43	60	107	●	●	●	○	●
12.80	14	43	60	107	○	●	●	○	●
13.00	14	43	60	107	●	●	●	○	●
13.30	14	43	60	107	○	●	●	○	●
13.50	14	43	60	107	●	●	●	○	●
13.80	14	43	60	107	○	●	●	○	●
14.00	14	43	60	107	●	●	●	○	●
14.20	16	45	65	115	●	●	●	○	●
14.50	16	45	65	115	●	●	●	○	●
14.60	16	45	65	115	●	●	●	○	●
15.00	16	65	65	115	●	●	●	○	●
15.30	16	65	65	115	○	●	●	○	●
15.50	16	65	65	115	●	●	●	○	●
15.80	16	65	73	115	○	●	●	○	●

● stock standard ○ non-standard stock ■ stock exhaustion

- TYPHOON
- C-SD-TA
- LFTA
- SUTA
- HSS-HSS/CO DRILLS
- UH RED
- MEX ORANGE
- HF EVO
- MEF ENDLESS
- ALU
- MDC
- G2
- MDTA
- ULTRA MILLS
- HSS/CO
- CARBIDE BURRS
- PARAMETERS