

	OSAWA NORM	5XD 355SU 355SUH	8XD 358SUH	12XD 3512SUH
PAGE 246				

(m7)					
Ø mm	1~3	3.1~6	6.1~10	10.1~18	18.1~20
tol. D µ	+12 / +2	+16 / +4	+21 / +6	+25 / +7	+29 / +8

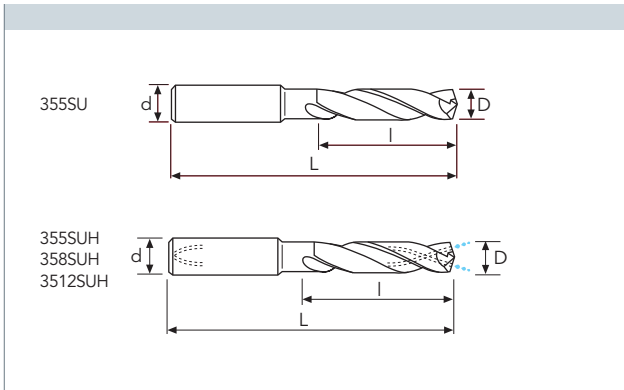

PV300	PV300	PV300	PV300

D(m7)	d(h6)	l	L	Stock	Stock	Stock	Stock
mm 1.70	3	11.1	55	○	○	●	○
1.70	3	16.2	60				
1.70	3	23	65				
1.75	3	11.4	55	○	○	○	○
1.75	3	16.6	60				
1.80	3	11.7	55	○	○	●	
1.80	3	17.1	60				●
1.80	3	24.3	65				
1.85	3	12	55	○	○		
1.85	3	17.6	60			●	
1.90	3	12.4	55	○	○	○	
1.90	3	18.1	60			●	
1.90	3	25.7	65			○	
1.95	3	12.7	55	○	○		
1.95	3	18.5	60				○
2.00	3	13	55	○	○	●	
2.00	3	19	60				●
2.00	3	27	65				●
2.05	3	13.3	55	○	○		
2.05	3	19.5	60			○	
2.10	3	13.7	55	○	○		
2.10	3	20	60			●	
2.10	3	28.4	65				●
2.15	3	14	55	○	○		
2.15	3	20.4	60			○	
2.20	3	14.3	55	○	○	●	
2.20	3	20.9	60				
2.20	3	29.7	65				●
2.25	3	14.6	55	○	○		
2.25	3	21.4	60			○	
2.30	3	15	55	○	○		
2.30	3	21.9	60			●	
2.30	3	31.1	65				○
2.35	3	15.3	55	○	○		
2.35	3	22.3	60			○	
2.40	3	15.6	55	○	○		

● stock standard ○ non-standard stock ■ stock exhaustion

- TYPHOON
- C-SD-TA
- LFTA
- SUTA
- HSS-HSS/CO DRILLS
- UH RED
- MEX ORANGE
- HF EVO
- MEF ENDLESS
- ALU
- MDC
- G2
- MDTA
- ULTRA MILLS
- HSS/CO
- CARBIDE BURRS
- PARAMETERS